

HIGH SECURITY ROAD BLOCKER

Original guide

OPERATION AND MAINTENANCE MANUAL. PART II. ELECTRICAL CONNECTION OF ROAD BLOCKERS (SERIES RB)

for automatic anti-ram blockers with external hydraulic unit

Electronic control unit RB106

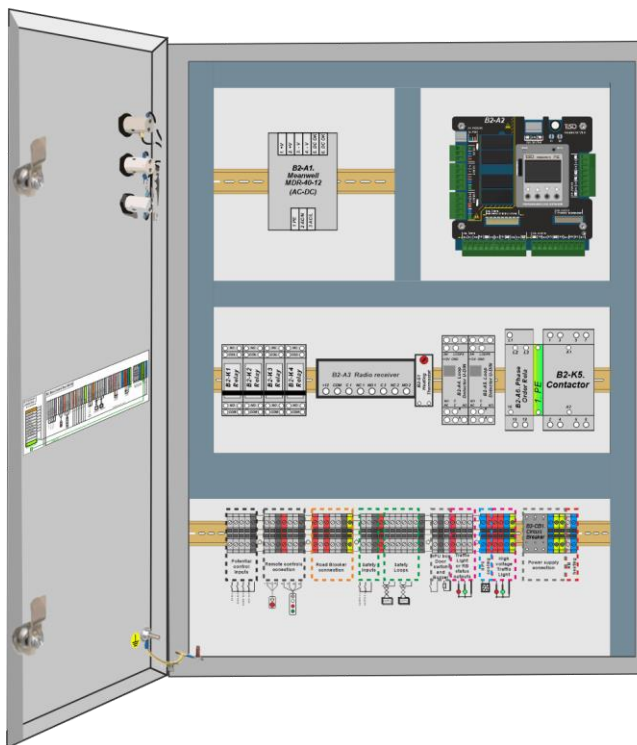

Electronic control unit RB107

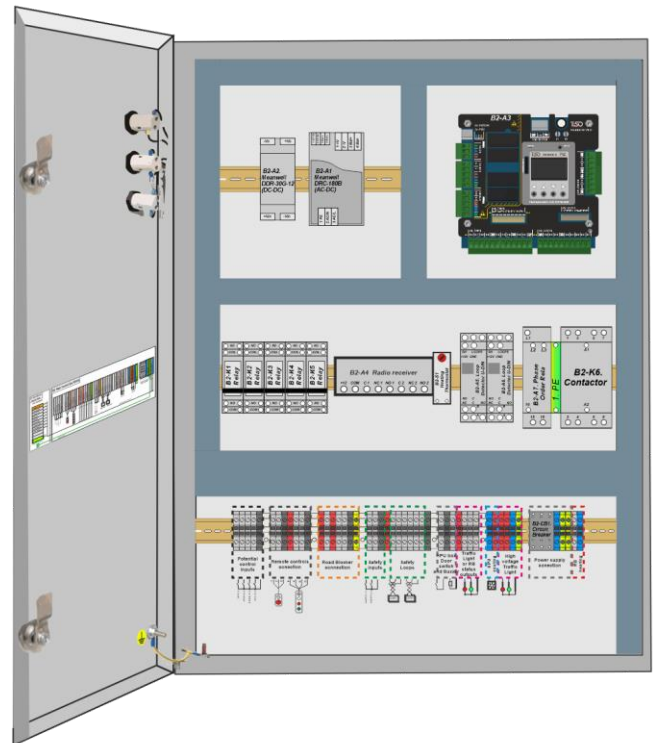

Зміст

INTRODUCTION.....	3
1. DESCRIPTION OF THE MAIN CONTROL COMPONENTS AND ELECTRICAL PARTS OF THE ROAD BLOCKER.....	4
1.1 The main control components and electrical parts of a Road Blocker.....	4
1.2 Control cabinet with ECU and HU	5
1.3 Classification of electronic control units depending on selected functions	6
2. PURPOSE AND OPERATION OF ELECTRONIC CONTROL UNITS.....	6
2.1. Appearance and placement ECU RB106 / RB106.1 / RB107 / RB107.1	6
2.2. Description of the structural diagram ECU RB106, RB106.1 and RB107, RB107.1	7
2.3. Components of the Electrical Schematic of the ECU	10
2.4. Components of the electrical diagram of the hydraulic unit	12
2.5 Connection of the Hydraulic Unit (HU) to the Electronic Control Unit (ECU)	13
3. CONNECTING THE BLOCKER AND EXTERNAL DEVICES TO THE ELECTRONIC CONTROL UNIT	15
3.1 Connection of the Electronic Control Unit to the Power Supply	16
3.2 Connecting the Road blocker (Connection cable) to the control unit	17
3.3 Connection of the access control system (Control panel, key fobs)	18
3.3.1 Connection of the access control system.....	18
3.3.2 TiSO control panels	18
3.3.2.1. Connection of TiSO control panels via RS485 interface	20
3.3.2.2. Connecting the remote control to potential control inputs	22
3.3.3 Radio receiver (OPTION *1)	25
3.4 Protective induction loops (OPTION *3).....	26
3.5 Connecting the UPS (Battery*) Function for ECU 107 and 107.1	30
3.6 Connecting the Traffic Light Option.....	33
3.7 Oil Heating Option in the Hydraulic System - *2.....	34
3.8 Oil Cooling Option in the Hydraulic System - *7.....	34
3.9 Connection of the Phase Order Relay Option - *4.....	34
4. PCB.350 TISO controller as a component of the electronic control unit.....	35
4.1 Description of the PCB.350 controller.....	35
4.2 Purpose of the connectors of the controller PCB350.02	35
4.3 Display for viewing settings and configurations of the PCB 350 controller.....	36
5. SYSTEM OPERATION CHECK	39
6. POSSIBLE MALFUNCTIONS AND TROUBLESHOOTING METHODS	41
Annex 1. - Wiring diagram of the Road Blockers to control unit RB106+EFO rev. 1.4.....	43
Annex 2. - Wiring diagram of the Road Blockers to control unit RB107+UPS+EFO rev. 1.4	44
Annex 3. - Wiring diagram of the Road Blockers to control unit RB106.1+EFO rev. 1.4.....	45
Annex 4. – Wiring diagram of the Road Blockers to control unit RB107.1+UPS+EFO rev. 1.4	46
Annex 5. – Diagram of connection of the Road Blockers to control unit RB106 / RB107 / RB106.1 / RB107.1	47

INTRODUCTION



The Road Blockers be installed and connected to control unit, power supply network and other devices only by certified professionals strictly observing electrical and mechanical safety regulations!

This Manual must be scrutinized prior to the Road Blocker installation, connection, putting into operation and maintenance!

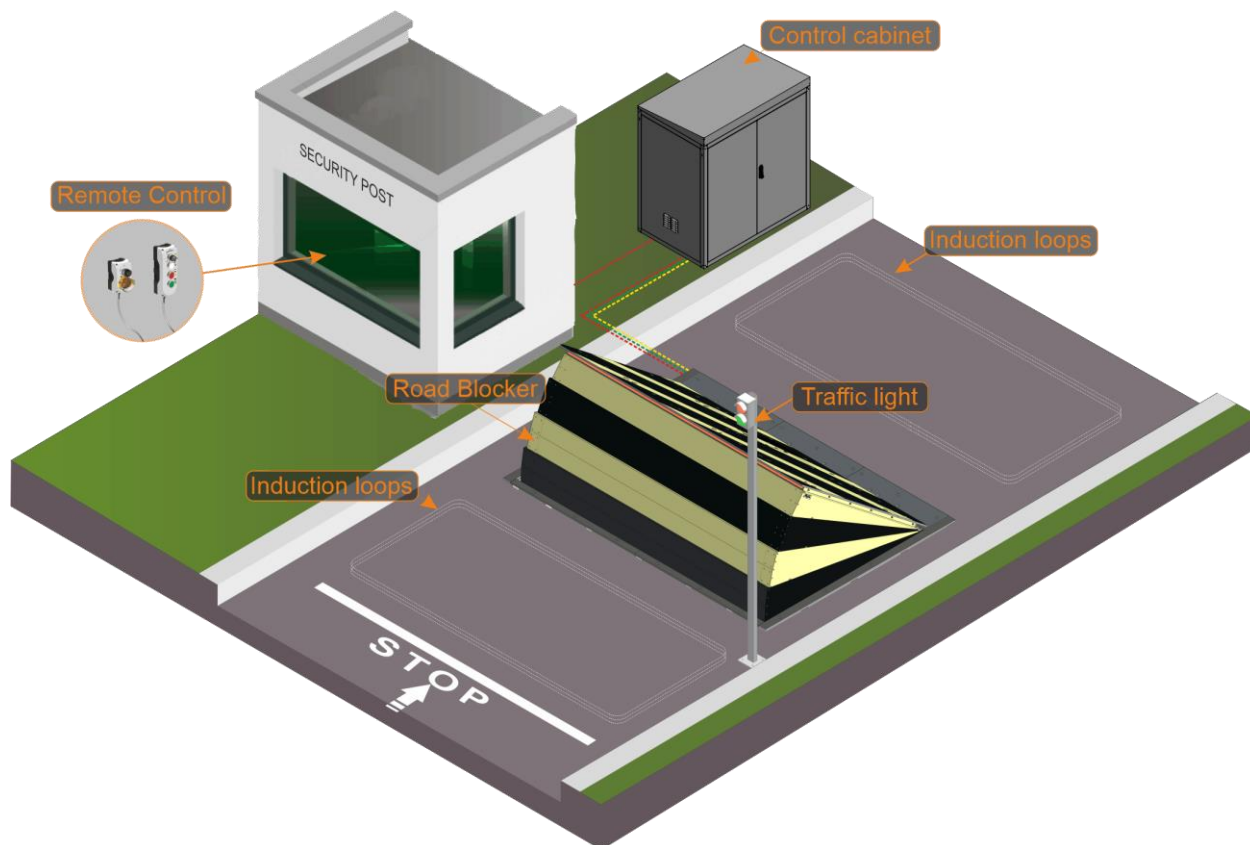

Fig.1. Access control system for a protected area

ROAD BLOCKING SYSTEMS



Office and Production site:
14 Promyslova str., 02088, Kyiv, Ukraine,
E-mail: sales@tiso.global

Tel.: +380 (44) 291-21-11
Fax: +380 (44) 291-21-02
www.tiso.global

1. DESCRIPTION OF THE MAIN CONTROL COMPONENTS AND ELECTRICAL PARTS OF THE ROAD BLOCKER

1.1 The main control components and electrical parts of a Road Blocker

The Road Blocker include **external hydraulic unit**. The control unit is assembled a box and is located in the external hydraulic unit cabinet.

Accordingly electrical control cables and two hydraulic hoses are connected from the external hydraulic unit cabinet to the Road Blocker.

The distance from the external hydraulic unit equipped with control unit to the Road Blocker is defined by allowable length of hydraulic hoses.

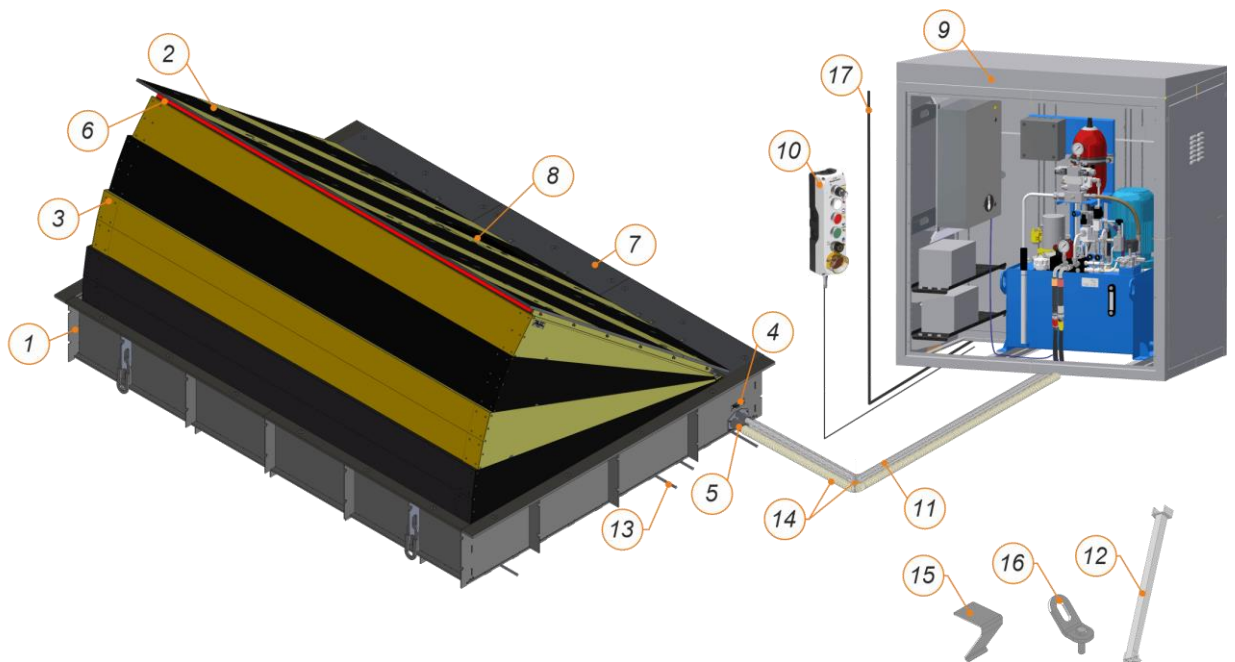

Legend:

- | | |
|--|--|
| 1. Static part (SP) – Road Blocker assembly; | 10. Remote Control; |
| 2. Dynamic part (DP) – Rising platform; | 11. Cable connecting (OLFLEX CLASSIC 12x0,75); |
| 3. Safety skirt; | 12. Service strut; |
| 4. Table; | 13. Reinforcement cage (optional); |
| 5. Place for entering communications; | 14. Hydraulic high-pressure hoses (HPH); |
| 6. LED indication; | 15. Gripping bracket for safety skirt; |
| 7. Audit hatch; | 16. Set of eyebolts for slinging cargo; |
| 8. Hydraulic cylinder; | 17. Power cable (400V – 3 phase 50/60 Hz) |
| 9. Control cabinet with HU and ECU: | |
| - Hydraulic unit (HU); | |
| - Electronic control unit (ECU); | |

Fig.2. Main components of Road Blocker and control cabinet

HIGH SECURITY ROAD BLOCKER

1.2 Control cabinet with ECU and HU

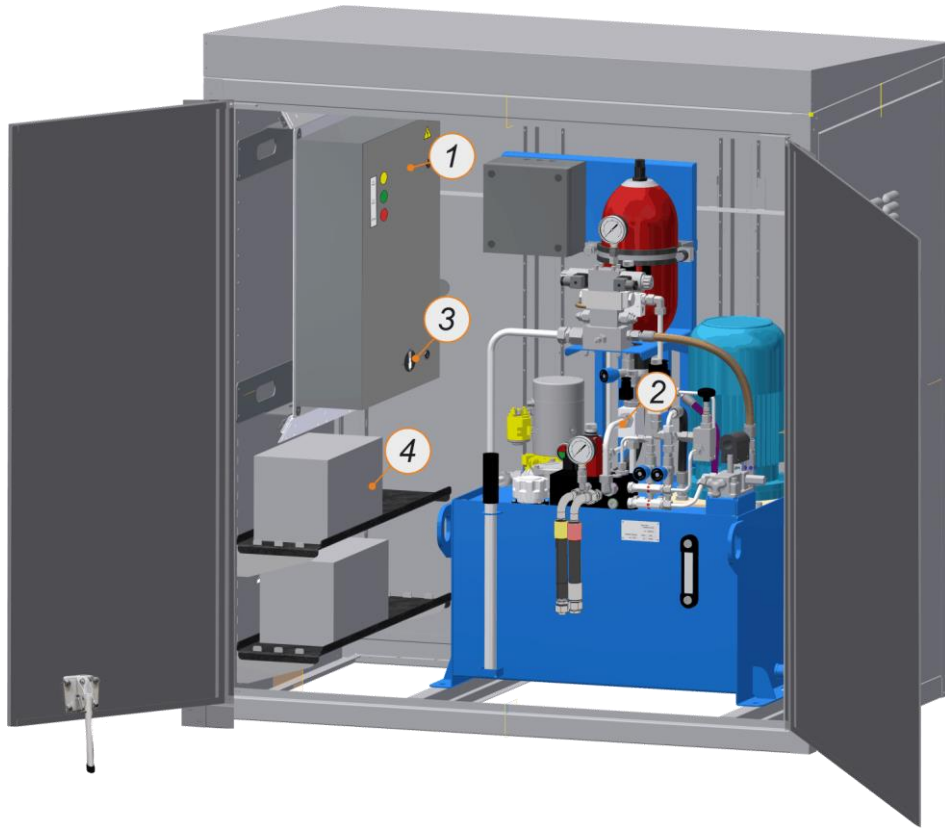

Legend:

1. Electronic control unit (ECU) RB106 / RB106.1 / RB107 / RB107.1
2. Hydraulic unit
3. Main power switch
4. UPS (uninterruptible power supply)
5. Door lock

Unlocking the cabinet doors:

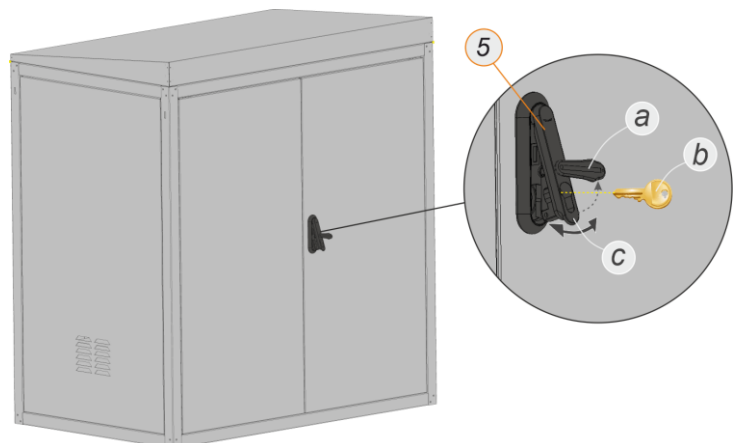

Fig.3. Assembly of road blocker control cabinet

HIGH SECURITY ROAD BLOCKER

1.3 Classification of electronic control units depending on selected functions

Power supply / Availability of UPS option	1 phase 230VAC	3 phase 400VAC
-	RB106.1	RB106
Option UPS	RB107.1	RB107

2. PURPOSE AND OPERATION OF ELECTRONIC CONTROL UNITS

2.1. Appearance and placement ECU RB106 / RB106.1 / RB107 / RB107.1

The Road Blocker electric control unit is a controller with auxiliary electric parts and is designed to control them.

The control unit is assembled in metal box. The Road Blocker power supply and control signals are connected to the control unit and electrical control cable and protective earthing cable are connected to the Road Blocker from control unit.

In general one control unit can control fully independently two independent homogeneous Road Blockers. All control units are assembled based on the versatile controllers PCB350.02.

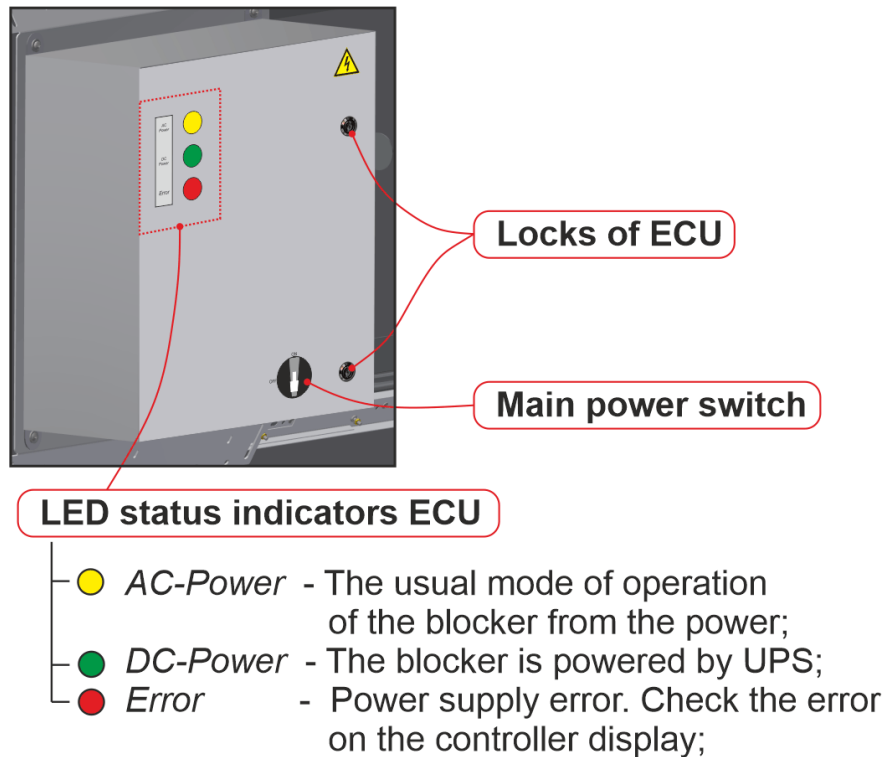

Fig.4. Appearance of the electronic control unit in the cabinet

HIGH SECURITY ROAD BLOCKER

2.2. Description of the structural diagram ECU RB106, RB106.1 and RB107, RB107.1

The **Electronic Control Unit (ECU)** is a set of electronic components that can be divided into groups, each serving its own functional purpose.

There are two types of control units, which are identical in their functional purpose but slightly differ in their component structure.

RB106 / RB106.1 – Standard control unit **without UPS option.**

RB107 / RB107.1 – Control unit **with UPS option.**

Electronic control unit RB106, RB106.1 without UPS option

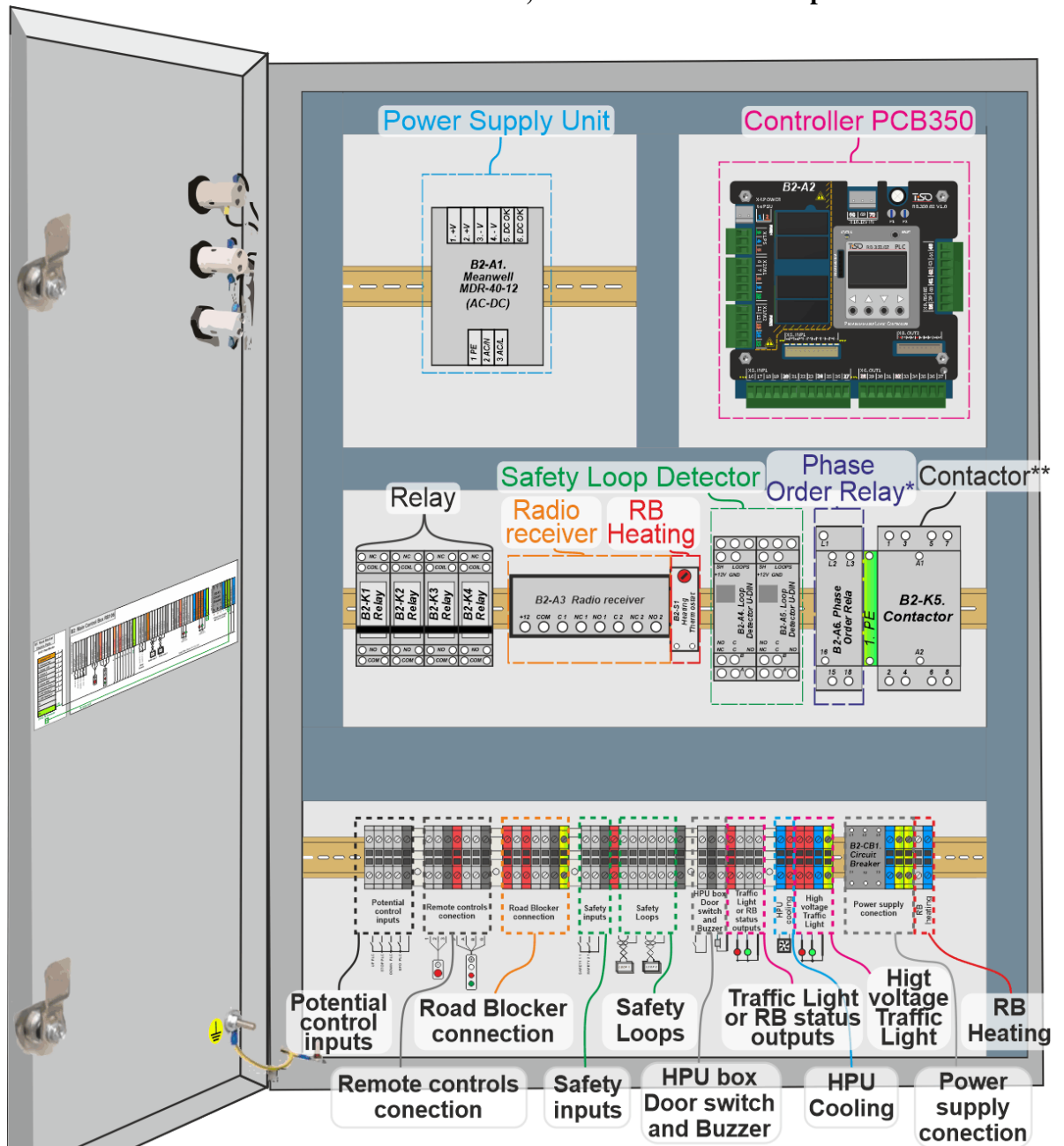

Fig.5. Main components of the electronic control unit RB106, RB106.1

ROAD BLOCKING SYSTEMS



HIGH SECURITY ROAD BLOCKER

Electronic control unit RB107, RB107.1 with UPS option

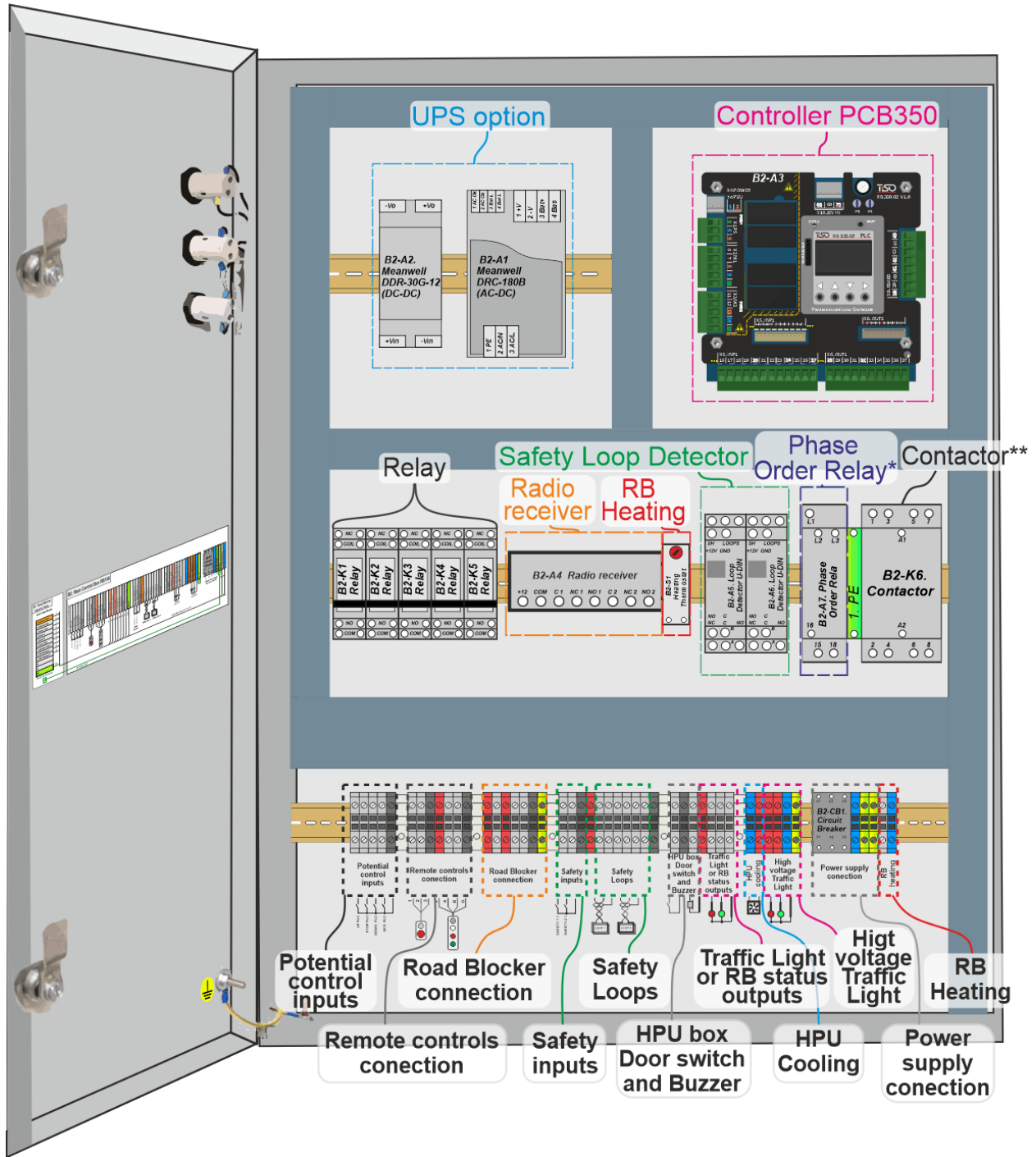

Fig.6. Main components of the electronic control unit RB107, RB107.1

*The Phase Order Relay option is used only in ECU RB106 and RB107

**In ECUs RB106 and RB107, 4-pole contactor is used, while in RB106.1 and RB107.1 — 2-pole contactor is installed.

ROAD BLOCKING SYSTEMS



HIGH SECURITY ROAD BLOCKER



Attention!

The difference between the **RB106.1** and **RB106** diagram lies in the following:

- 1) The power section is single-phase. In this version, the control unit is equipped with a single-phase electric motor instead of a 3-phase asynchronous motor, and a different motor contactor is used.
- 2) The “Phase Order Relay” option is not installed.

The **RB107.1** diagram has the same differences compared to the **RB107**.

All other components in these diagram remain the same.

Since the device with the RB107/RB107.1 control unit is designed to operate from a battery in the absence of main power supply, all components of the diagram are powered by +24 V. In this configuration, all solenoid valves operate at +24 V. The main motor contactor is also powered by the same voltage. A key feature of the B2-A1 power supply unit is the built-in UPS function. This means the power supply automatically detects the absence of input voltage and switches to backup battery power. Because the PCB350 controller and the hydraulic system control relays operate at a nominal voltage of +12 V, a DC-DC converter from +24 V to +12 V is also installed in the control unit.

The RB106/RB106.1 control units do not include a UPS option and use a simpler power supply system. This version includes a single power supply that converts 230 V to +12 V for powering all components. In this configuration, different solenoid valves are used, which operate at 230 V AC.

Table 1 - Description of Main Components of the Electronic Control Unit

<i>N^o</i>	<i>Name of the Block (Terminals)</i>	<i>Function</i>
1	Controller PCB350.02	TiSO Controller for Blocker Operation and Configuration
2	Power Supply Unit	Power Supply
3	UPS option (RB107)	Optional UPS (Uninterruptible Power Supply) Battery Back-up for Power-off Situation
4	Relay Group	Relay (Hydraulic System)
5	Radio receiver (*1)	Optional Remote Radio Control
6	RB Heating (*2)	Thermostat with Regulator
7	Safety loop detector (*3)	Loop Detector for Vehicle Presence and Passage Detection
8	Phase Order Relay (*4)	Optional Phase Order Relay
9	Contactor	Main Contactor (for Motor Activation)
10	Main terminal block	Main Terminal Block B2-X1

All external components are connected to the ECU via the terminal block B2-X1.

The following are connected to these terminals:

- 1) Power supply and protective grounding cable of the road blocker;
- 2) External control signals for the device;
- 3) Indication and feedback sensors from the actuator part of the road blocker.

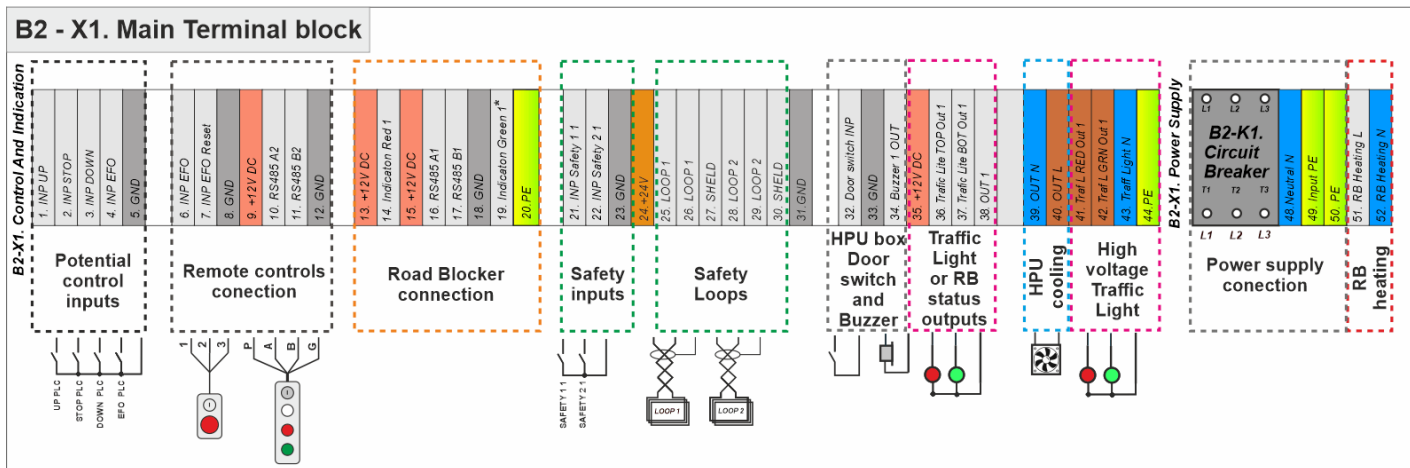

Fig.7 – Main terminal block ECU

Table 2 - Function of individual sections of the Main Terminal Block

№	Name of the Terminal Block B2-X1	Function
1	Potential control inputs	External Control Signal Connection
2	Remote control connection	Remote control unit connection
3	Road Blocker connection	Connection of Communications with the Road Blocker
4	Safety inputs	Infrared barrier detector connection
5	Safety loops	Optional safety induction loop connection
6	HPU box door switch input	Limit switch connection
7	HPU box buzzer output	Alarm signal for low oil level or high oil temperature
8	Traffic light or RB status outputs	Traffic light outputs or status outputs for upper/lower blocker positions
9	HPU cooling	Cooling system option
10	High voltage traffic light	Relay output for high-voltage traffic light connection
11	Power supply connection	Power supply connection for the road blocker
12	RB heating	Road blocker heating option

2.3. Components of the Electrical Schematic of the ECU

The electrical schematic of the Electronic Control Unit (ECU) includes both mandatory components and optional features. Components related to optional features are marked accordingly on the schematic. The list of all options and their designations is provided below:

- Emergency Fast Operation – *EFO
- Radio receiver – *1
- Heating thermostat – *2
- Loop detector – *3
- Phase Order Relay – *4
- Door switch – *5
- Buzzer – *6
- Cooling – *7

HIGH SECURITY ROAD BLOCKER

Table 3 provides a description of all components of the electrical diagram for RB106, RB106.1, RB107, and RB107.1. All diagram variants are shown in **Anex 1–4**.

Table 3 - Name and purpose of the components of the ECU diagram.

№	Designation		Component name		Purpose	
	RB106	RB107	RB106	RB107	RB106	RB107
1	B2-A1		Meanwell MDR-40-12 (AC-DC)	Meanwell DRC-180B (AC-DC)	Main power supply. Input: 230V, output: 12V.	Main power supply with built-in UPS option. Input: 230V, output: 24B.
2	-	B2-A2	-	Meanwell DDR-30G-12 (DC-DC)	DC-DC step-down voltage converter. Used to convert 24V DC to 12V DC.	
3	B2-A2	B2-A3	PLC RB350		Universal programmable logic controller TISO PLC RB350.	
4	B2-A3 <i>*1</i>	B2-A4 <i>*1</i>	Radio receiver		Signal receiver SATEL RXH-4K for radio control option	
5	B2-A4 <i>*3</i>	B2-A5 <i>*3</i>	Safety loop detector U-DIN 1		Vehicle detector ULTRA-DIN based on an induction loop. ULTRA-DIN vehicle loop detector.	
6	B2-A5 <i>*3</i>	B2-A6 <i>*3</i>	Safety loop detector U-DIN 2		Vehicle detector ULTRA-DIN based on an induction loop. ULTRA-DIN vehicle loop detector.	
7	B2-A6 <i>*4</i>	B2-A7 <i>*4</i>	Phase order relay		Relay for determining the correct phase connection order.	
8	B2-K1		Relay		Relay for switching the main electric motor contactor.	
9	B2-K2		Relay		Relay for switching the slowdown electromagnetic valve.	
10	B2-K3 <i>*EFO</i>		Relay		Relay for switching the lifting electromagnetic valve in the EFO system.	
11	B2-K4		Relay		Relay for switching the additional electric motor contactor. UPS option.	
12	B2-K4	B2-K5	Relay		Relay for controlling 230V traffic light.	
13	B2-K5	B2-K6	Main motor contactor		Main electric motor contactor.	
14	B2-L1		DC power green indicator		12V power presence indicator in the diagram.	
15	B2-L2		AC power yellow indicator		AC power presence indicator at the input.	
16	B2-L3		ERROR red indicator		Error indicator.	
17	B2-S1 <i>*2</i>		Heating thermostat		Thermostat with a regulator.	
18	B2-CB1		Circuit breaker		3-phase power switch.	
19	B2-X1		Control and indication terminal block		Main terminal block for connecting control signals and external indicators of the device.	
			Power supply terminal block		Terminal block for connecting the power supply of the road blocker.	

HIGH SECURITY ROAD BLOCKER

2.4. Components of the electrical diagram of the hydraulic unit

An essential component of the Road Blocker is the external hydraulic unit, which is installed in the HU cabinet. The operation of the HU is controlled by signals from the ECU to the solenoid valves and by supplying power to the electric motor. The control unit is assembled in a box and located in the external cabinet of the hydraulic station. Accordingly, the control electrical cables and two hydraulic hoses are connected from the external hydraulic block cabinet to the road blocker. The distance from the external hydraulic station, equipped with the control unit, to the road blocker is determined by the permissible length of the hydraulic hoses. Table 4 lists all the electrical components of the HU.

Table 4 - Name and purpose of the HU components.

№	Designation		Component name		Purpose	
	RB106	RB107	RB106	RB107	RB106	RB107
1	-	B3-B1	-	2 x 12V battery	-	Backup batteries for the UPS system.
2	B3-M1		Main AC motor 3-phase		Asynchronous AC electric motor.	
3	-	B3-M2	-	24V DC motor	-	Additional electric motor for the UPS system.
4	-	B3-M3	-	24V DC FAN	-	Cooling fan for the UPS system electric motor.
5	-	B3-K1	-	24V DC motor contactor	-	Contactor for the additional UPS electric motor.
6	B3-Y1		Valve R1.1 Up		Electromagnetic valve of the HU.	
7	B3-Y2		Valve R1.2 Down		Electromagnetic valve of the HU.	
8	B3-Y3 <i>*EFO</i>		Valve R2 EFO charging		Electromagnetic valve of the HU.	
9	B3-Y4 <i>*EFO</i>		Valve R3 EFO rise up		Electromagnetic valve of the HU.	
10	B3-Y5		Valve R4 damping		Electromagnetic valve of the HU.	
11	B3-S1 <i>*EFO</i>		EFO pressure sensor		Pressure sensor in the hydraulic accumulator.	
12	B3-S2		Low oil level sensor		Low oil level sensor.	
13	B3-S3		High oil temperature sensor		High oil temperature sensor.	
14	B3-S4 <i>*5</i>		Door switch		Open door sensor of the HU cabinet.	
15	B3-M4 <i>*7</i>		Cooling fan		Cooling fan for the HU cabinet.	
16	B3-S5 <i>*7</i>		Thermostat		Thermostat for the HU cabinet cooling system.	
17	B3-S5 <i>*6</i>		BUZZER		Buzzer to attract attention.	
18	B3-H1 <i>*2</i>		Heater		Heater for the HU tank.	
19	B3-X1		Motor terminal block		Terminal block for connecting the main electric motor.	

HIGH SECURITY ROAD BLOCKER

Continuation of the table 4

20	B3-X2	Electromagnetic valves terminal block		Terminal block for connecting the HU electromagnetic valves.
21	B3-X3	Sensors terminal block		Terminal block for connecting the HU feedback sensors.
22	-	B3-X4	24V DC UPS Motor terminal block	Terminal block for connecting the additional UPS electric motor.
23	B3-X5	Cooler/buzzer terminal block		Terminal block for connecting the cooling system and buzzer.

2.5 Connection of the Hydraulic Unit (HU) to the Electronic Control Unit (ECU)

The hydraulic unit is a separate component of the blocker system. The connection of all electrical components of the hydraulic unit (HU) to the Electronic Control Unit (ECU) is carried out through terminal blocks located in the distribution box on the HU itself. Power and signal conductors are connected directly from the ECU components to the HU terminal blocks. Tables 5 and 6 describe all connections between the ECU and the HU.

Table 5 - Connection of HU to the ECU according to the diagram RB106

№	Connecting to the ECU RB106	Terminal name	Electrical component name HU
B3-X1. Motor			
1	B2-K5	Motor L1	B3-M1. Main AC motor 3-phase
2		Motor L2	
3		Motor L3	
4	B2-K5.1.PE	Motor PE	
B3-X2. Valves			
1	B2-A2; X2.M1; Out 6	Valve R1.1 UP L	B3-Y1. Valve R1.1 (UP)
2	B2-A2; X2.M1; Out 7	Valve R1.2 DOWN L	B3-Y2. Valve R1.2 (DOWN)
3	B2-A2; X3.M2; Out 11	Valve R2 EFO Chrg L	B3-Y3. Valve R2 (EFO charging)
4	B2-K3; NO	Valve R3 EFO UP L	B3-Y4. Valve R3 (EFO Rise UP)
5	B2-K2; NO	Valve R4 Damping L	B3-Y5. Valve R4 (Damping)
6	B2-X1. Power Supply; 48.N	Valve R1.1 UP N	B3-Y1. Valve R1.1 (UP)
7		Valve R1.2 DOWN N	B3-Y2. Valve R1.2 (DOWN)
8		Valve R2 EFO Chrg N	B3-Y3. Valve R2 (EFO charging)
9		Valve R3 EFO UP N	B3-Y4. Valve R3 (EFO Rise UP)
10		Valve R4 Damping N	B3-Y5. Valve R4 (Damping)

ROAD BLOCKING SYSTEMS



HIGH SECURITY ROAD BLOCKER

Continuation of the table 5

11-15	B2-X1. Power Supply; 49.N	Valve PE	B3-Y*
B3-X3. Sensors			
1	-	Pressure SW NC	B3-S1. EFO pressure sensor
2	B2-A2; X5.INP1; Inp 20	Pressure SW COM	
3	B2-A2; X5.INP1; Inp 23	Pressure SW NO	
4	B2-A2; X7.INP1; Inp 46	Low oil SW NO	B3-S2. Low oil level sensor
5	B2-A2; X5.INP1; Inp 20	Low oil SW COM	
6	-	Oil Temperature SW NC	B3-S3. High oil temperature sensor
7	B2-A2; X5.INP1; Inp 20	Oil Temperature SW COM	
8	B2-A2; X7.INP1; Inp 47	Oil Temperature SW NO	
9	B2-X1. Power Supply; 49.N	Sensors PE	B3-S*

Table 6 - Connection of HU to the ECU according to the diagram RB107

№	Connecting to the ECU RB107	Terminal name	Electrical component name HU
B3-X1. Motor			
1	B2-K6	Motor L1	B3-M1. Main AC motor 3-phase
2		Motor L2	
3		Motor L3	
4	B2-K6.1.PE	Motor PE	
B3-X2. Valves			
1	B2-A2; X2.M1; Out 6	Valve R1.1 UP +24V	B3-Y1. Valve R1.1 (UP)
2	B2-A2; X2.M1; Out 7	Valve R1.2 DOWN +24V	B3-Y2. Valve R1.2 (DOWN)
3	B2-A2; X3.M2; Out 11	Valve R2 EFO Chrg +24V	B3-Y3. Valve R2 (EFO charging)
4	B2-K3; NO	Valve R3 EFO UP +24V	B3-Y4. Valve R3 (EFO Rise UP)
5	B2-K2; NO	Valve R4 Damping +24V	B3-Y5. Valve R4 (Damping)
6	GND	Valve R1.1 UP GND	B3-Y1. Valve R1.1 (UP)
7		Valve R1.2 DOWN GND	B3-Y2. Valve R1.2 (DOWN)
8		Valve R2 EFO Chrg GND	B3-Y3. Valve R2 (EFO charging)
9		Valve R3 EFO UP GND	B3-Y4. Valve R3 (EFO Rise UP)
10		Valve R4 Damping GND	B3-Y5. Valve R4 (Damping)

ROAD BLOCKING SYSTEMS



HIGH SECURITY ROAD BLOCKER

Continuation of the table 6

B3-X3. Sensors			
1	-	Pressure SW NC	B3-S1. EFO pressure sensor
2	B2-A3; X5.INP1; Inp 20	Pressure SW COM	
3	B2-A3; X5.INP1; Inp 23	Pressure SW NO	
4	B2-A3; X7.INP1; Inp 46	Low oil SW NO	B3-S2. Low oil level sensor
5	B2-A3; X5.INP1; Inp 20	Low oil SW COM	
6	-	Oil Temperature SW NC	B3-S3. High oil temperature sensor
7	B2-A3; X5.INP1; Inp 20	Oil Temperature SW COM	
8	B2-A3; X7.INP1; Inp 47	Oil Temperature SW NO	
B3-X4. 24V DC UPS Motor			
1	B2-A1; 4.Bat-	GND	B3-M2. 24V DC motor
2	B2-A1; 3.Bat+	+24V DC	
3	B2-K4; NO	A1	B3-K1. 24V DC motor contactor

3. CONNECTING THE BLOCKER AND EXTERNAL DEVICES TO THE ELECTRONIC CONTROL UNIT



ATTENTION!

The Control unit has a built-in power supply interrupter on the power voltage input. But it does not have a built-in automatic circuit breaker from overload with a residual current circuit breaker or a differential automaton.

The Road Blocker (and hydraulic station) is installed on the street (outside) and is subject to atmospheric influences.

The control unit of the Road Blocker must necessarily be connected to the power supply through the Differential automat (for example ABB DS 204 AC)

Or through the circuit breaker from overload (for example PL4 Eaton) together with the Residual current circuit breaker (RCCB) (for example PF6 Eaton).

One or two Road Blockers are installed on roadbed. Control unit is located in metal box inside the external hydraulic unit cabinet. Electric cables and two hydraulic hoses are connected from the external hydraulic unit to the Road Blocker.

Each Road Blocker is connected to control unit with one control electric cable **JZ-500 12x0,75** and one **PE** cable **PV 1x2.5**.

The **RB106-107** control units are connected to a **3-phase 400V AC** power supply, the **RB106-107** control units are connected to a **1-phase 230V AC** power supply network through installed in a convenient location circuit breaker from overload with an RCCB or a differential automat. The current of such differential automat is chosen based on the power consumed by the hydrostation.

Control signals (for example, access control system), remote control panel B2-A1. Remote Control Panel (optional), emergency "Stop" button Remote Emergency Push Button "Stop" and actuating devices, for example, traffic lights, external siren, are also connected to control unit.

Wiring diagram of the Road Blockers to control unit **RB106, RB106.1, RB107, RB107.1** and auxiliary devices is shown in **Annex 1-4**.

Diagram of connection of the Road Blockers to control unit **RB106, RB106.1, RB107, RB107** is shown in **Annex 5**.

HIGH SECURITY ROAD BLOCKER

3.1 Connection of the Electronic Control Unit to the Power Supply

After completing all the main connections to the electronic control unit, it is necessary to connect the main power cable and supply voltage by switching on the power switch in the control cabinet.



During connection of 3-phase power supply network 400V AC care should be taken not to confuse phases L1, L2, L3 of 3-phase power supply network with neutral N or protective earthing PE, otherwise the Road Blocker control unit fails.

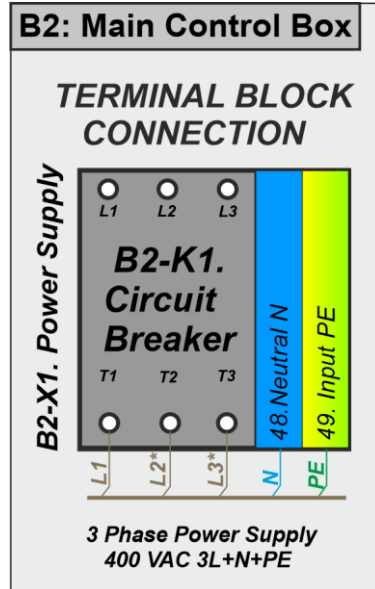

Провід	Power Supply (Terminal block B2-X1 on the diagram)
1	1.Power Supply Input L1
2	2.Power Supply Input L2
3	3.Power Supply Input L3
4	4.Power Supply Input N
5	5.PE

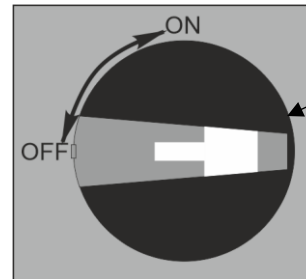

Main power switch on the Control Unit (ECU)

Fig. 8 – Wiring Diagram for Connecting the Control Unit (ECU) to the Power Supply



3-phase motor is used in the Road Blockers with **3-phase 400VAC** power supply, rotation direction of which during raising and sinking depends on polarity of phases **L1, L2, L3**. When the Road Blocker is activated for the first time, then "UP" and "DOWN" commands to be generated and the Road Blocker proper movement to be observed. If the Road Blocker does not move, then any two phases on the industrial network voltage input to be changed, e.g. "L1" and "L2". Thus the Road Blocker movement direction should comply with the required one.



THE MOTOR ROTATION DIRECTION MUST BE CLOCKWISE!

To change the direction of rotation, swap any two phases.

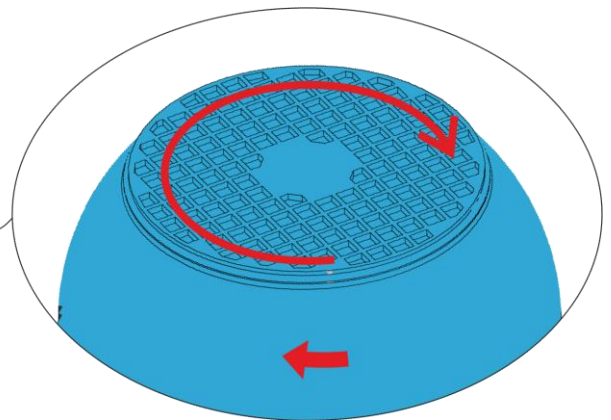

*L2, L3 are connected only in ECU RB106, RB107 (3 phase 400VAC)

ROAD BLOCKING SYSTEMS



Office and Production site:
14 Promyslova str., 02088, Kyiv, Ukraine,
E-mail: sales@tiso.global

Tel.: +380 (44) 291-21-11
Fax: +380 (44) 291-21-02
www.tiso.global

HIGH SECURITY ROAD BLOCKER

3.2 Connecting the Road blocker (Connection cable) to the control unit

The moving part of the blocker also contains electrical components that are connected to the ECU (Electronic Control Unit) using 12-core **JZ-500 12x0,75** cable. The cross-sectional area of each conductor is 0.75 mm². This cable is used to connect the +12V LED lighting and the angular position sensor **DI-602**.

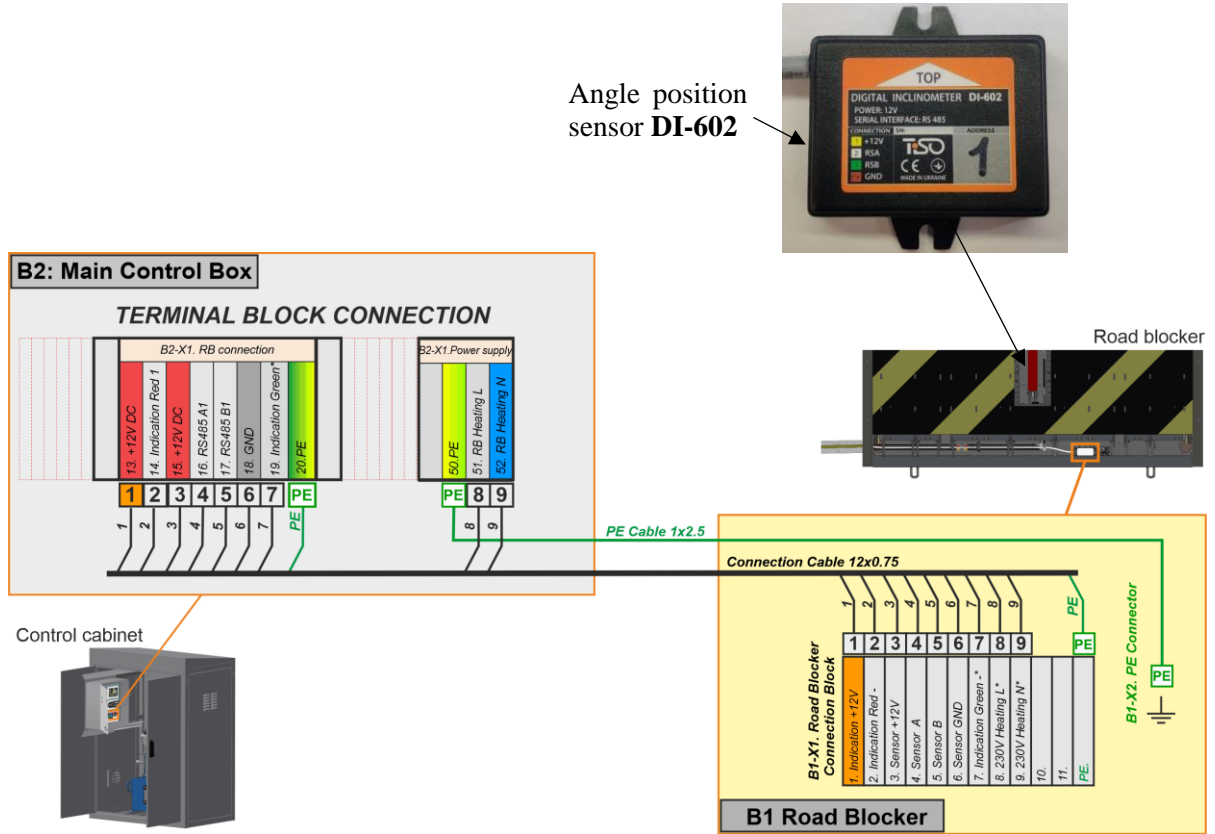

Fig. 9 – Wiring Diagram for Connecting the Road blocker to the ECU

Table 7 – Connecting the Road blocker to the ECU RB106/RB107

Cable wires number	B2 Electronic control unit	B1 Road blocker
	B2-X1. terminal block	B1-X1 terminal block
1	13. +12V DC Outputs 1	1. Indication +12V
2	14. Indication Red 1	2. Indication Red -
3	15. +12V DC	3. Sensor +12V
4	16. RS485 A1	4. Sensor A
5	17. RS485 B1	5. Sensor B
6	18. GND	6. Sensor GND
7	19. Indication Green*	7. Indication Green-*
8	51.RB Heating L	8. 230V Heating L*
9	52. RB Heating N	9. 230V Heating N*
PE	20. PE	PE
		B1-X2. terminal block
PE	50.PE	PE Connector

*Option

ROAD BLOCKING SYSTEMS



After connecting the blocker to the control unit, you can proceed with connecting the access control system and control panels:

- Wired Remote Control Unit (АЮИА.115) to B2-X1;
- Wired industrial remote control units to B2-X1:
Remote controls АЮИА.112-20, АЮИА.112-30, АЮИА.112-40, АЮИА.112-50, АЮИА.113-40 or АЮИА.113-60.
- Remote Emergency Push Button "Stop" (АЮИА.112-10) to B2-X1.
- Traffic light to B2-X1.

3.3 Connection of the access control system (Control panel, key fobs)

3.3.1 Connection of the access control system

The road blocker can operate not only independently but also as part of an access control system. For example, it can be integrated into a sluice system consisting of multiple blockers or a combination of a blocker and a boom barrier. In such cases, the ECU has a separate group of potential inputs of the "dry contact" type.

Table 8 - Inputs for connecting the access control system.

№	Name of the output on terminal block B2-X1	Purpose
1	INP UP	Command to raise the blocker.
2	INP STOP	Emergency stop command for the blocker.
3	INP DOWN	Command to lowering the blocker.
4	INP EFO	Command for emergency raising using the hydraulic accumulator (Emergency Fast Operation option).
5	GND	Common ground.

3.3.2 TiSO control panels

A wired control panel (CP) can be used to operate the road blocker.

Let's examine the structure of the panel АИИА.115 and the control algorithm of the blocker.

In general, for blockers without the EFO (Emergency Fast Operation) option, the control panel includes pairs of identical buttons: "UP" – to raise, "STOP" – to stop, and "DOWN" – to lower.

Road Blocker is raised when "UP" button is pushed. The lamp near "UP" button will be blinking during raising. When Road Blocker reaches the uppermost position and stops, then the lamp near "UP" button will be steadily lit - UP position display.

Road Blocker is sunk when "DOWN" button is pushed. The lamp near "DOWN" button will be blinking during sinking. When Road Blocker reaches the lowermost position and stops, then the lamp near "DOWN" button will be steadily lit - DOWN position display.

Road Blocker is stopped when "STOP" button is pushed during raising or lowering.

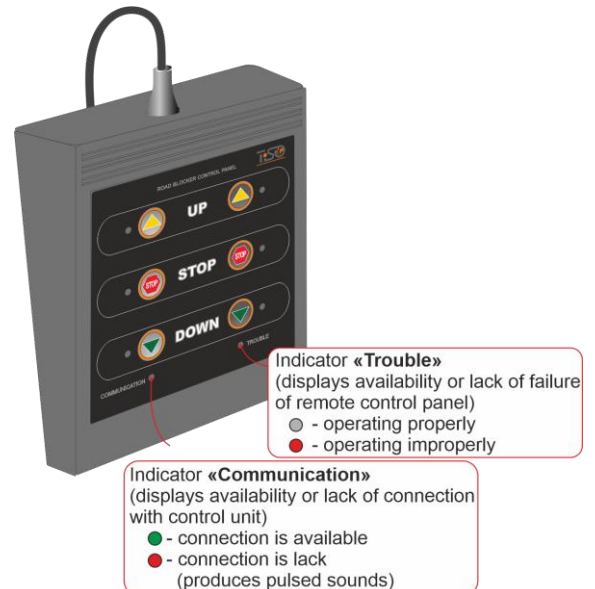

Fig.10 - Control Panel АИИА.115 (example АИИА.115-01)

The remote control panel **RB115** is equipped with built-in Road Blocker movement alarm and produces harmonic signals during Road Blocker raising and sinking.

If the blocker is equipped with the **EFO** (Emergency Fast Operation) option, the pair of identical "STOP" and "DOWN" buttons remains the same. The left "UP" button functions as usual and performs the standard "UP" operation. However, the right "UP" button is used to trigger the emergency fast raising operation – **EFO** (Control Panel AUIA.115-02).

Let's examine the structure of the panel **AUIA.113-60** and the control algorithm of the blocker:

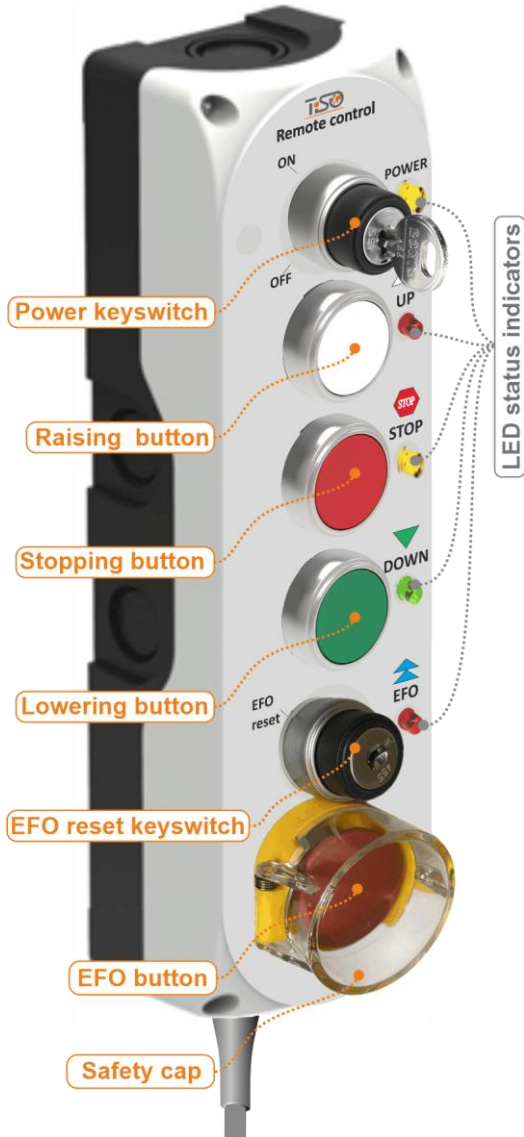

Fig.11 – Structure of the Industrial Control Panel (example AUIA.113-60)

1. Power keyswitch

The key is turned to the ON POWER position for activated remote control panel. The yellow indicator will light up.

*This function is added to the system in order to prevent the road blocker from being operated by people other than the guard staff in case of emergency.

2. Raising button

Raising of the road blocker is done automatically.

In order to raise it automatically, push "UP" white button once. During the lifting of the blocker platform - the indicator flashes red.

3. Lowering button

Lowering of the road blocker is done automatically.

In order to lower it automatically, push "DOWN" green button once. During the lowering of the blocker platform - the indicator flashes green.

4. Stopping button

To stop raising or lowering the platform, push the red "STOP" button.

5. EFO button (EMERGENCY FAST OPERATION):

In case of emergency, optional Emergency Fast Operation feature raises the road blocker to fully up position in less than 1 second, thanks to high-pressured accumulator.

This feature is activated by the panic button on remote control keyboard

- Open the safety cap.
- Press the red button EFO to raise the blocker platform emergency fast operation!

At that time, all modes of operation of the road blocker will be blocked!





6. EFO reset keyswitch





To restore normal control operation and enable operating all modes, and the button "EFO" to be ready for the next emergency raising of the platform, it is necessary:

- Insert the key into the keyswitch
- Turn the key to the EFO reset position and backward in first position
- Remove the key

HIGH SECURITY ROAD BLOCKER

Table 9 - TiSO Remote Control Panels

Control panel group with RS 485 interface connection			
AUIA.115-01 RC-RS-6b.U-S-D+6LED	AUIA.115-02 RC-RS-6b.U-S-D-EFO +6LED	AUIA.113-40 RCI-RS-3b.U-S-D+1k.P+4LED	AUIA.113-60 RCI-RS-4b.U-S-D-EFO-SC+2k.R-P+5LED
			

Control panel group connected to potential inputs				
AUIA.112-10 RCI-D-1b.EFO	AUIA.112-20 RCI-D-1b.EFO-SC+1k.R	AUIA.112-30 RCI-D-3b.U-S-D	AUIA.112-40 RCI-D-4b.U-S-D-EFO	AUIA.112-50 RCI-D-4b.U-S-D-EFO-SC+1k.R
				



Control Panels of type AUIA.113-XX – AUIA.115-XX differ in that they have indicators showing the status of the blocker. These panels are connected to the ECU via the RS485 interface.

Control Panels of type AUIA.112-XX do not have blocker status indicators and are connected to potential-free inputs. A feature of this type of control panel is the ability to connect them directly to multiple ECU blockers.

3.3.2.1. Connection of TiSO control panels via RS485 interface

Various remote control panels may be supplied with a TiSO-manufactured blocker. However, the connection method for branded panels is always the same. Data transmission between these panels is carried out via the RS485 interface, which is a standard for industrial equipment. The remote control panel is supplied with a 4-core cable, 2 meters in length. It can be extended up to 500 meters using a twisted pair cable.

ROAD BLOCKING SYSTEMS



HIGH SECURITY ROAD BLOCKER

If the blocker model is equipped with the EFO option, one possible solution is the use of a dedicated control panel with an emergency lifting button (AUIA.112-10, AUIA.112-20).





Control panel group with RS 485 interface connection			
AUIA.115-01 RC-RS-6b.U-S-D+6LED	AUIA.115-02 RC-RS-6b.U-S-D-EFO +6LED	AUIA.113-40 RCI-RS-3b.U-S-D+1k.P+4LED	AUIA.113-60 RCI-RS-4b.U-S-D-EFO-SC+2k.R-P+5LED
			

Table 10 – Connecting the industrial control panel (RS485) to the ECU

Control cabinet



Remote control

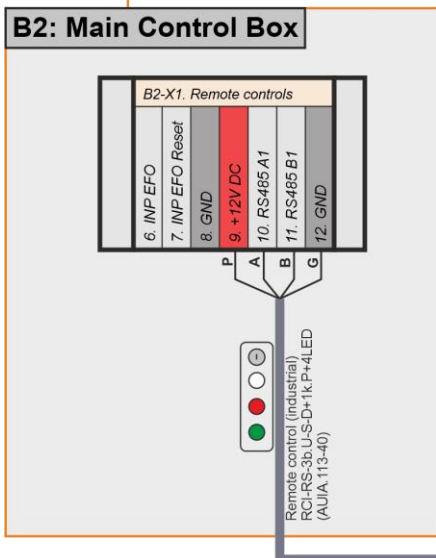

Wire	Terminal block B2-X1. Remote controls part (in the ECU diagram)
P	9. +12V DC
A	10. RS485 A1
B	11. RS485 B1
G	12. GND

Fig. 12 - Connecting the industrial control panel to the ECU (example AUIA.113-40 RCI-RS-3b.U-S-D+1k.P+4LED)

ROAD BLOCKING SYSTEMS



Office and Production site:
14 Promyslova str., 02088, Kyiv, Ukraine,
E-mail: sales@tiso.global

Tel.: +380 (44) 291-21-11
Fax: +380 (44) 291-21-02
www.tiso.global

HIGH SECURITY ROAD BLOCKER

3.3.2.2. Connecting the remote control to potential control inputs

Blockers can be controlled both by proprietary TiSO control panels and by third-party devices. For control from an external system, dedicated inputs are provided in the ECU unit.





Control panel group connected to potential inputs				
AUIA.112-10 RCI-D-1b.EFO	AUIA.112-20 RCI-D-1b.EFO-SC+1k.R	AUIA.112-30 RCI-D-3b.U-S-D	AUIA.112-40 RCI-D-4b.U-S-D-EFO	AUIA.112-50 RCI-D-4b.U-S-D-EFO-SC+1k.R
				

Table 11 – Connection of control panels to «dry contact» inputs

№	Output Name on Terminal Block B2-X1	Purpose
Control panel connection inputs AUIA.112-10, AUIA.112-20		
6	INP EFO	Command for emergency raising using the hydraulic accumulator (Emergency Fast Operation option)
7	INP EFO Reset	System reset command after emergency fast operation
8	GND	Common Ground



ROAD BLOCKING SYSTEMS

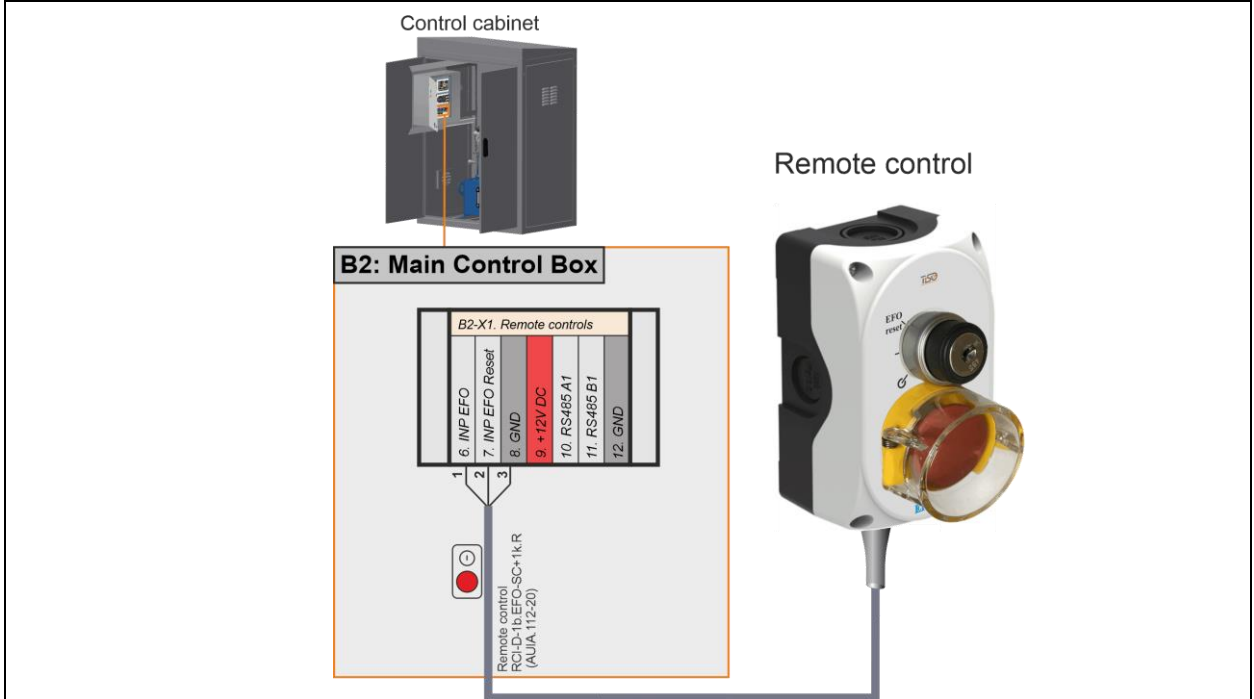

HIGH SECURITY ROAD BLOCKER

Control panel connection inputs IY AUIA.112-30

1	INP UP	Command to Raise the Blocker
2	INP STOP	Emergency Stop Command for the Blocker
3	INP DOWN	Command to Lower the Blocker
5	GND	Common Ground



Control cabinet



Remote control

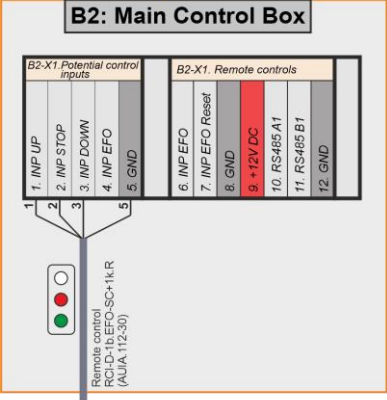

B2: Main Control Box

B2-X1. Potential control inputs					B2-X1. Remote controls																		
1	INP UP	2	INP STOP	3	INP DOWN	4	INP EFO	5	GND	6	INP EFO	7	INP EFO Reset	8	GND	9	+12V DC	10	RS485 A1	11	RS485 B1	12	GND

Remote control: RCI-D-16-EFO-SC-14-R (AUIA.112-30)

Control panel connection inputs AUIA.112-40

1	INP UP	Command to Raise the Blocker
2	INP STOP	Emergency Stop Command for the Blocker
3	INP DOWN	Command to Lower the Blocker
4	INP EFO	Command for emergency raising using the hydraulic accumulator (Emergency Fast Operation option)
5	GND	Common Ground



Control cabinet



Remote control

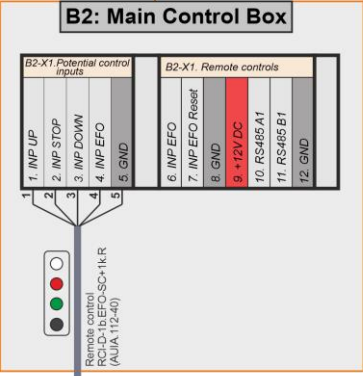

B2: Main Control Box

B2-X1. Potential control inputs					B2-X1. Remote controls																		
1	INP UP	2	INP STOP	3	INP DOWN	4	INP EFO	5	GND	6	INP EFO	7	INP EFO Reset	8	GND	9	+12V DC	10	RS485 A1	11	RS485 B1	12	GND

Remote control: RCI-D-16-EFO-SC-14-R (AUIA.112-40)

ROAD BLOCKING SYSTEMS



HIGH SECURITY ROAD BLOCKER

Control panel connection inputs AUIA.112-50		
1	INP UP	Command to Raise the Blocker
2	INP STOP	Emergency Stop Command for the Blocker
3	INP DOWN	Command to Lower the Blocker
4	INP EFO	Command for emergency raising using the hydraulic accumulator (Emergency Fast Operation option)
5	GND	Common Ground
6	INP EFO	Command for emergency raising using the hydraulic accumulator (Emergency Fast Operation option)
7	INP EFO Reset	System reset command after emergency fast operation
8	GND	Common Ground

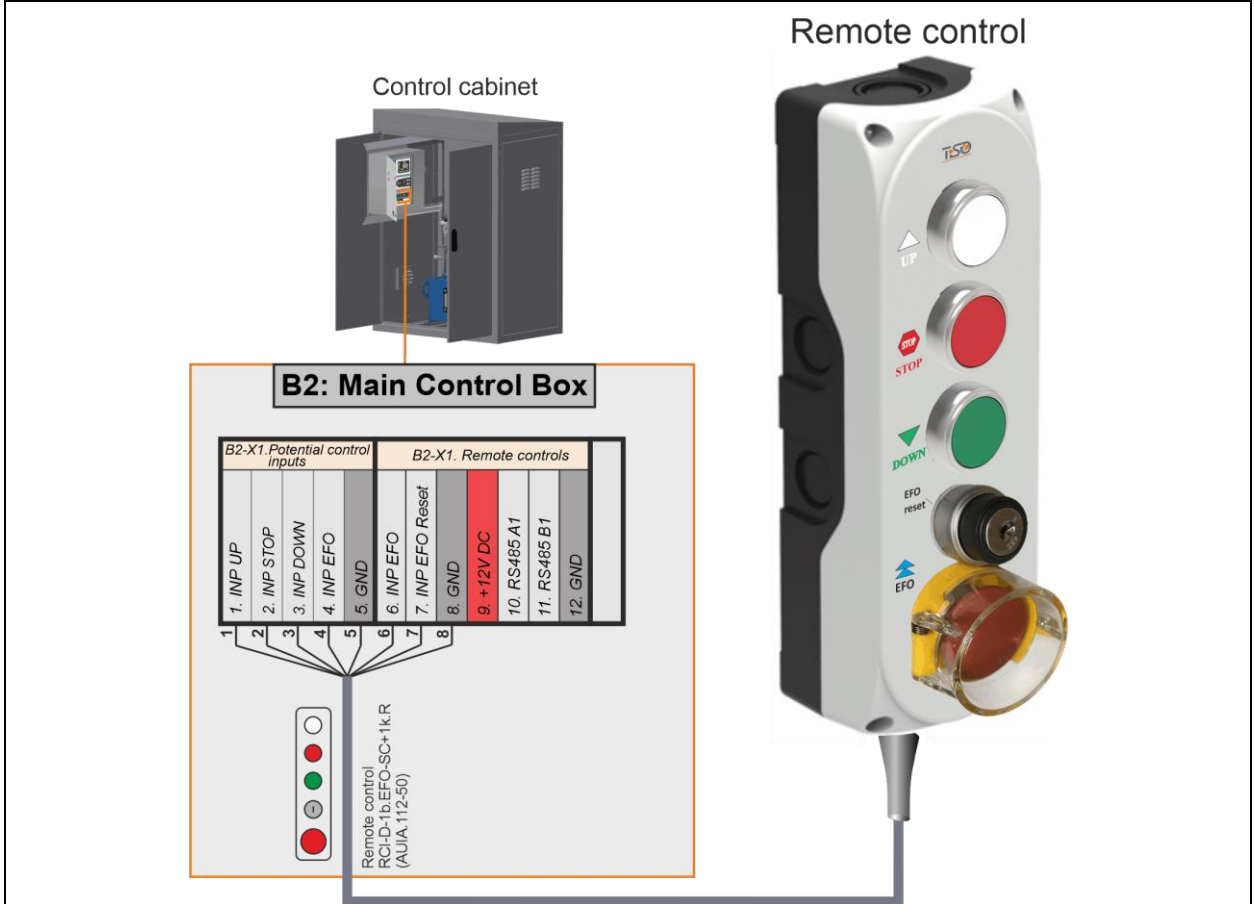

ROAD BLOCKING SYSTEMS



Office and Production site:
14 Promyslova str., 02088, Kyiv, Ukraine,
E-mail: sales@tiso.global

Tel.: +380 (44) 291-21-11
Fax: +380 (44) 291-21-02
www.tiso.global

HIGH SECURITY ROAD BLOCKER

3.3.3 Radio receiver (OPTION *1)

The Road Blocker control unit may include additional option – **Road Blocker wireless control by remote control key fobs.**

For this option, a radio signal receiver is additionally installed in the ECU. The set also includes 2 remote control key fobs — Satel T-2. In the ECU diagram, the radio signal receiver is designated as B2-A3. Wireless Remote Controller Satel RE-2K.

Maximum allowable distance from remote control key fob to control unit is **25 m.**

Table 12 - Radio control receiver connector designations

№	Radio receiver terminal	Component Name		Terminal Name
		RB106	RB107	
1	SS	Not used		-
2	+12V	+12 V		+12 V
3	COM	GND		GND
4	C1	GND		GND
5	NC1	Not used		-
6	NO1	B2-A2, X5.INP1	B2-A3, X5.INP1	16
7	C2	GND		GND
8	NC2	Not used		-
9	NO2	B2-A2, X5.INP1	B2-A3, X5.INP1	18

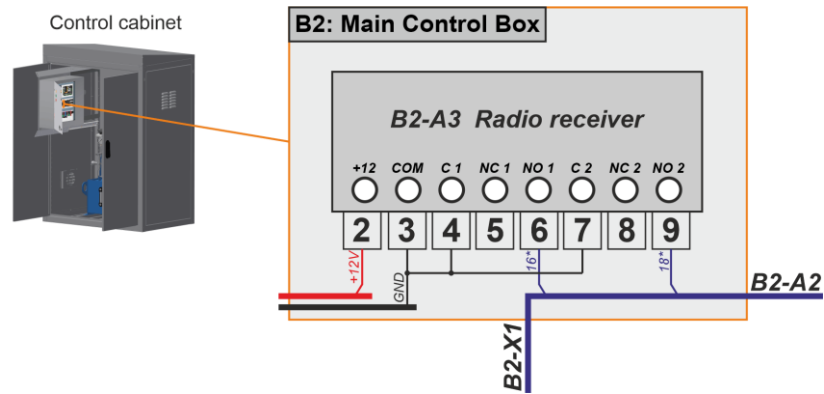

Fig. 13 - Connection of the radio receiver option in the ECU



Fig. 14 - Remote control key fobs Satel T-2 Fig. 15 - Radio receiver controller Satel RE-2K

HIGH SECURITY ROAD BLOCKER

Green "UP" button of remote control pendant **Satel T-2** to be pushed to **raise** the Road Blocker.
Red "DOWN" button of remote control pendant **Satel T-2** to be pushed to **sink** the Road Blocker.

To add new remote control pendants **Satel T-2** in storage of wireless controller **Satel RE-2K** it is necessary to open top cover and:

- 1) Programming button "PROGRAM" to be pushed – LED of wireless controller Satel RE-2K starts blinking green.
- 2) Any button of remote control pendant to be pushed – LED starts blinking red.
- 3) Button of remote control pendant to be repushed – LED is lit green.
- 4) Remote control pendant is added.

More details on wireless controller **Satel RE-2K** can be found on the manufacturer's website by reference: <https://www.satel.pl/en/produktid/483>.

3.4 Protective induction loops (OPTION *3)

The Road Blocker control unit may include additional option – **protective induction loops**.

One or two induction loops are installed in roadbed next to the Road Blockers, are connected to control unit and are used to prevent the Road Blocker raising when a vehicle is over it.

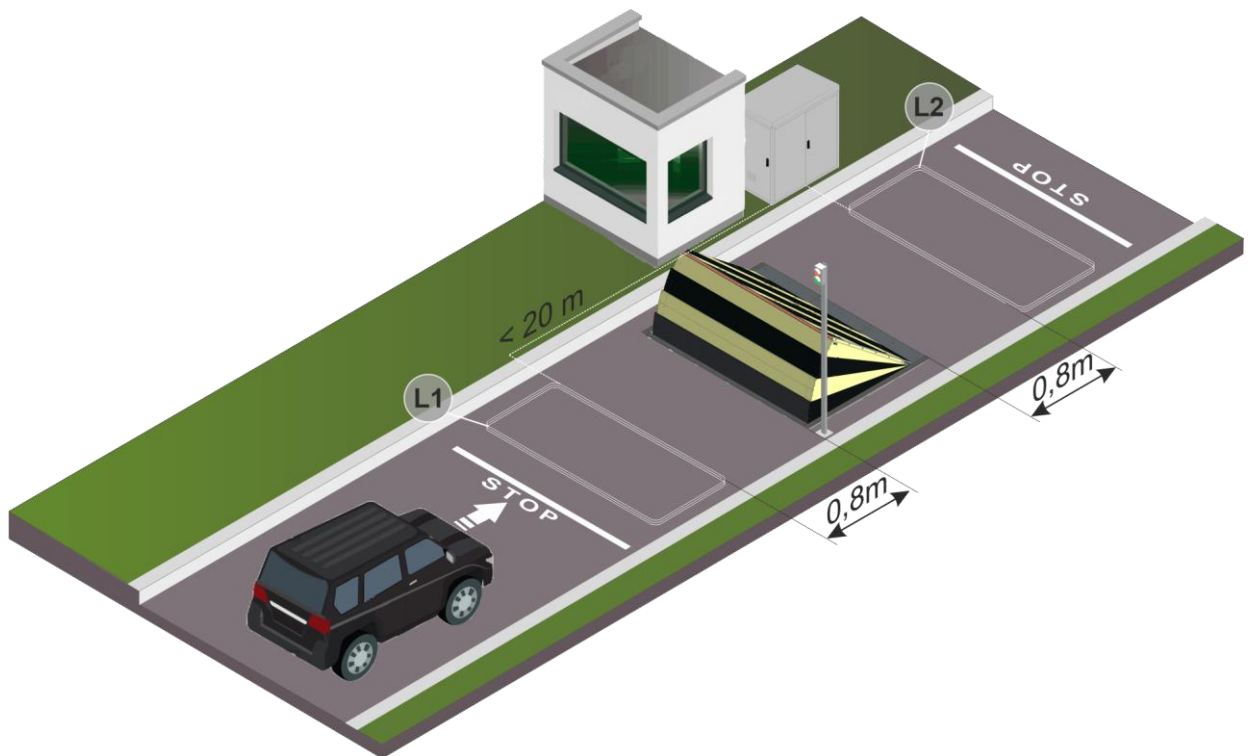
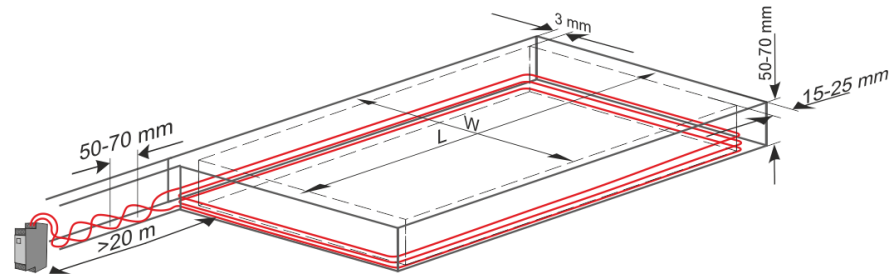

Fig.16 – Induction Loops in design position

HIGH SECURITY ROAD BLOCKER

Induction Loops in the Design Position



If a Road Blocker has **induction loop** option, then control unit contains one or two controllers of induction loops **B2-A4, B2-A5 (B2-A5, B2-A6 for ECU 107, 107.1) Safety Loop Detector A EMX ULTRADIN***

Kit may also include some cables **SIF1.0** for preparation of induction loops. Maximum allowable distance from induction loop to control unit is **20 m**.

Induction loop responds to vehicle metal and at its location there should not be metal in road surface. Minimum distance from induction loop to the Road Blocker metal parts is **500 mm**.

A trench of **50-70 mm** depth and **15-25 mm** width according to induction loop size is made for installation of induction loop in road surface. A trench is also made from the edge of induction loop to control unit.

Induction loop is **3-4** turns of cable **SIF1.0** to be installed in trench the ends of which are twisted between them and connected to induction loop controller of control unit. Cable **SIF1.0** can be laid in plastic corrugated tube or plastic pipe. After induction loop is laid in pipe it is filled with sand and covered with cement or asphalt grout.

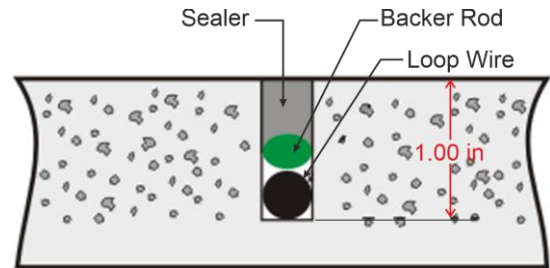

Table 13 - Contains recommended induction loop size, number of turns and vehicle detection height

Loop size Length	Loop size width	Turns	Detection Height Feet
2 (0.61m)	2 (0.61m)	5	1.6 (0.488m)
2 (0.61m)	4 (1.22m)	4	1.6 (0.488m)
2 (0.61m)	6 (1.83m)	4	1.6 (0.488m)
2 (0.61m)	8 (2.44m)	3	1.6 (0.488m)
2 (0.61m)	10 (3.05m)	3	1.6 (0.488m)
2 (0.61m)	12 (3.66m)	3	1.6 (0.488m)
2 (0.61m)	14 (4.27m)	3	1.6 (0.488m)
2 (0.61m)	16 (4.88m)	3	1.6 (0.488m)
2 (0.61m)	18 (5.49m)	3	1.6 (0.488m)
2 (0.61m)	20 (6.10m)	3	1.6 (0.488m)
4 (1.22m)	4 (1.22m)	4	3.2 (0.975m)
4 (1.22m)	6 (1.83m)	4	3.2 (0.975m)
4 (1.22m)	8 (2.44m)	3	3.2 (0.975m)
4 (1.22m)	10 (3.05m)	3	3.2 (0.975m)
4 (1.22m)	12 (3.66m)	3	3.2 (0.975m)
4 (1.22m)	14 (4.27m)	3	3.2 (0.975m)
4 (1.22m)	16 (4.88m)	3	3.2 (0.975m)
4 (1.22m)	18 (5.49m)	3	3.2 (0.975m)

ROAD BLOCKING SYSTEMS



HIGH SECURITY ROAD BLOCKER

Continuation of the table 13

4 (1.22m)	20 (6.10m)	3	3.2 (0.975m)
4 (1.22m)	22 (6.71m)	3	3.2 (0.975m)
4 (1.22m)	24 (7.32m)	3	3.2 (0.975m)
4 (1.22m)	26 (7.93m)	3	3.2 (0.975m)
4 (1.22m)	28 (8.54m)	3	3.2 (0.975m)
4 (1.22m)	30 (9.14m)	2	3.2 (0.975m)
4 (1.22m)	32 (9.75m)	2	3.2 (0.975m)
4 (1.22m)	33 (10.06m)	2	3.2 (0.975m)
4 (1.22m)	34 (10.36m)	2	3.2 (0.975m)
4 (1.22m)	36 (10.97m)	2	3.2 (0.975m)
4 (1.22m)	38 (11.58m)	2	3.2 (0.975m)
4 (1.22m)	40 (12.20m)	2	3.2 (0.975m)
6 (1.83m)	6 (1.83m)	4	4.8 (1.463m)
6 (1.83m)	8 (2.44m)	3	4.8 (1.463m)
6 (1.83m)	10 (3.05m)	3	4.8 (1.463m)
6 (1.83m)	12 (3.66m)	3	4.8 (1.463m)
6 (1.83m)	14 (4.27m)	3	4.8 (1.463m)
6 (1.83m)	16 (4.88m)	3	4.8 (1.463m)
6 (1.83m)	18 (5.49m)	3	4.8 (1.463m)
6 (1.83m)	20 (6.10m)	2	4.8 (1.463m)
6 (1.83m)	22 (6.71m)	2	4.8 (1.463m)
6 (1.83m)	24 (7.32m)	2	4.8 (1.463m)
6 (1.83m)	26 (7.93m)	2	4.8 (1.463m)
6 (1.83m)	28 (8.54m)	2	4.8 (1.463m)
6 (1.83m)	30 (9.14m)	2	4.8 (1.463m)
6 (1.83m)	32 (9.75m)	2	4.8 (1.463m)
6 (1.83m)	33 (10.06m)	2	4.8 (1.463m)
6 (1.83m)	34 (10.36m)	2	4.8 (1.463m)
6 (1.83m)	36 (10.97m)	2	4.8 (1.463m)
6 (1.83m)	38 (11.58m)	2	4.8 (1.463m)
6 (1.83m)	40 (12.20m)	2	4.8 (1.463m)
8 (2.44m)	4 (1.22m)	4	3.2 (0.975m)
8 (2.44m)	6 (1.83m)	4	4.8 (1.463m)
8 (2.44m)	8 (2.44m)	3	5.6 (1.71m)
8 (2.44m)	10 (3.05m)	3	5.6 (1.71m)
8 (2.44m)	12 (3.66m)	3	5.6 (1.71m)
8 (2.44m)	14 (4.27m)	3	5.6 (1.71m)
8 (2.44m)	16 (4.88m)	3	5.6 (1.71m)
8 (2.44m)	18 (5.49m)	2	5.6 (1.71m)
8 (2.44m)	20 (6.10m)	2	5.6 (1.71m)
8 (2.44m)	22 (6.71m)	2	5.6 (1.71m)
8 (2.44m)	24 (7.32m)	2	5.6 (1.71m)
8 (2.44m)	26 (7.93m)	2	5.6 (1.71m)
8 (2.44m)	28 (8.54m)	2	5.6 (1.71m)
8 (2.44m)	30 (9.14m)	2	5.6 (1.71m)
8 (2.44m)	32 (9.75m)	2	5.6 (1.71m)

ROAD BLOCKING SYSTEMS



HIGH SECURITY ROAD BLOCKER

Continuation of the table 13

8 (2.44m)	33 (10.06m)	2	5.6 (1.71m)
8 (2.44m)	34 (10.36m)	2	5.6 (1.71m)
8 (2.44m)	36 (10.97m)	2	5.6 (1.71m)
8 (2.44m)	38 (11.58m)	2	5.6 (1.71m)
8 (2.44m)	40 (12.20m)	2	5.6 (1.71m)

Two twisted ends of cable SIF1.0 of each induction loop to be connected to terminals "LOOP" and "LOOP" of Safety Loop Detector EMX ULTRADIN induction loop controller of control unit.

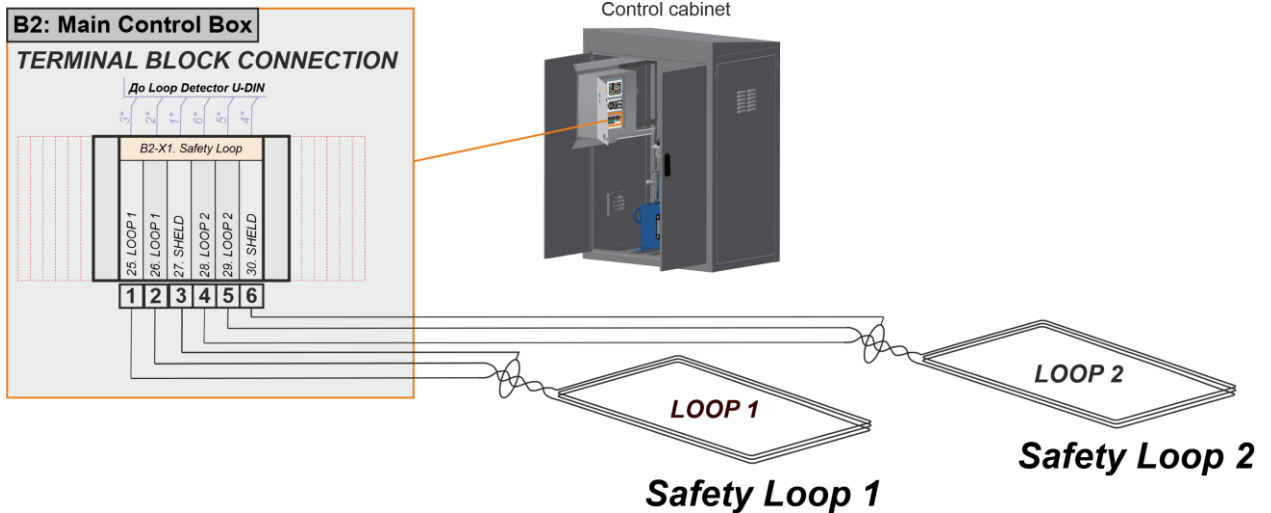

Fig. 17 - Connection of Induction Loops to the ECU

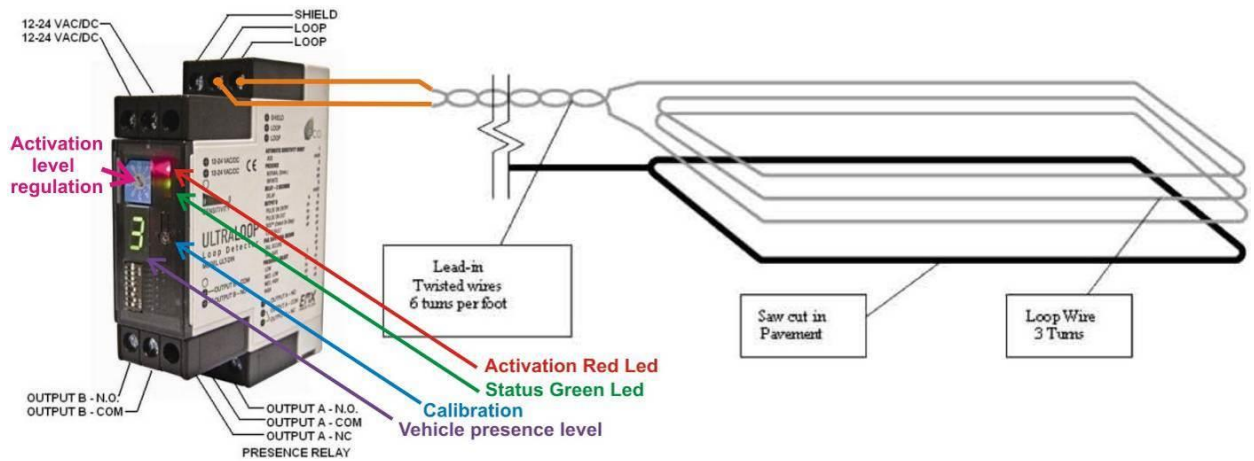

Fig.18 - Diagram of connection of induction loop to Safety Loop Detector EMX ULTRADIN induction loop controller of control unit

ROAD BLOCKING SYSTEMS



HIGH SECURITY ROAD BLOCKER



Terminal pin	Description
1	Shield – Earth Ground
2	Loop Connection
3	Loop Connection
4	Power 12-24 VDC/AC
5	Power 12-24 VDC/AC
6	No Connection
7	Output B – NO (normally open contact)
8	Output B – COM (common contact)
9	No Connection
10	Output A – NC (normally closed contact)
11	Output A – COM (common contact)
12	Output A – NO (normally open contact)

Fig.19 - Designation of Induction Loop Controller Connectors

After installing the induction loop, connecting it to the controller, and switching on the power, press the "Reset" button (5) and wait 10 seconds for the controller to calibrate.

Sensitivity setting (1) – the regulator position determines the vehicle presence level at which the detector is triggered. Typically, it is set to a value of 4–5.

ULTRAMETER display (4) – shows the sensitivity level when a vehicle is detected near the loop.

Red indicator (2) – indicates the presence of a vehicle on the loop.

Green indicator (3) – indicates that the detector is powered and operational.

DIP SWITCH (6) – switch for loop mode settings: Automatic Sensitivity Boost / Infinite Presence Mode / Delay Mode / Output B / Fail Safe Secure / Frequency Setting.

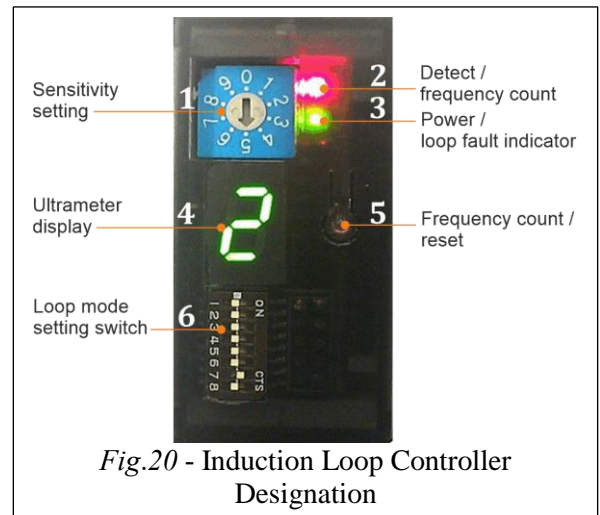

Fig.20 - Induction Loop Controller Designation

More details on induction loop controller **EMX ULTRADIN** can be found on the manufacturer's website by reference: <https://www.emxaccesscontrolsensors.com/product/ultra-din/>

3.5 Connecting the UPS (Battery*) Function for ECU 107 and 107.1

The road blocker is capable of operating in emergency situations during power outages if an additional uninterruptible power supply (UPS) function is connected. Its hydraulic station, in addition to the main 3-phase 400VAC electric motor, is equipped with an additional 24VDC electric motor powered by two 12VDC car batteries (60–100 Ah) connected in series.

The 12V 60–100 Ah batteries must be connected with the main power supply to the ECU switched off.

**Batteries are not included in the delivery package.*

ROAD BLOCKING SYSTEMS



HIGH SECURITY ROAD BLOCKER

Specifications of the connected batteries

Parameter	Value
Quantity	2 pcs (2 x 12VDC = 24VDC)
Battery type	Lead - acid
Operating voltage	12VDC
Capacity	60 ... 100 A/h
Starting current	> 500 A
Battery terminal dimensions	"+" - 19,5 mm; "-" - 17.9 mm (European type)
Maximum dimensions LxWxH	352 mm x 175 mm x 190 mm

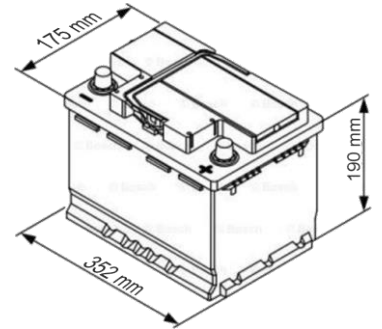

If you are using the UPS function, you need to connect 2 batteries to the terminals at the ends of the red and black cables in order to connect the batteries in series using the cable connector with fuse holder from the kit, according to the provided wiring diagram.



Attention!

Be careful when connecting the two batteries and installing them on the shelf in the hydraulic power unit cabinet. Follow the polarity and the connection sequence as shown in the wiring diagram! Incorrect connection may result in damage to the control unit.



The "+" terminal of the **FIRST** car battery must be connected to the **RED wire** with the "+" terminal for battery connection.

The "-" terminal of the **SECOND** car battery must be connected to the **BLACK wire** with the "-" terminal for battery connection.

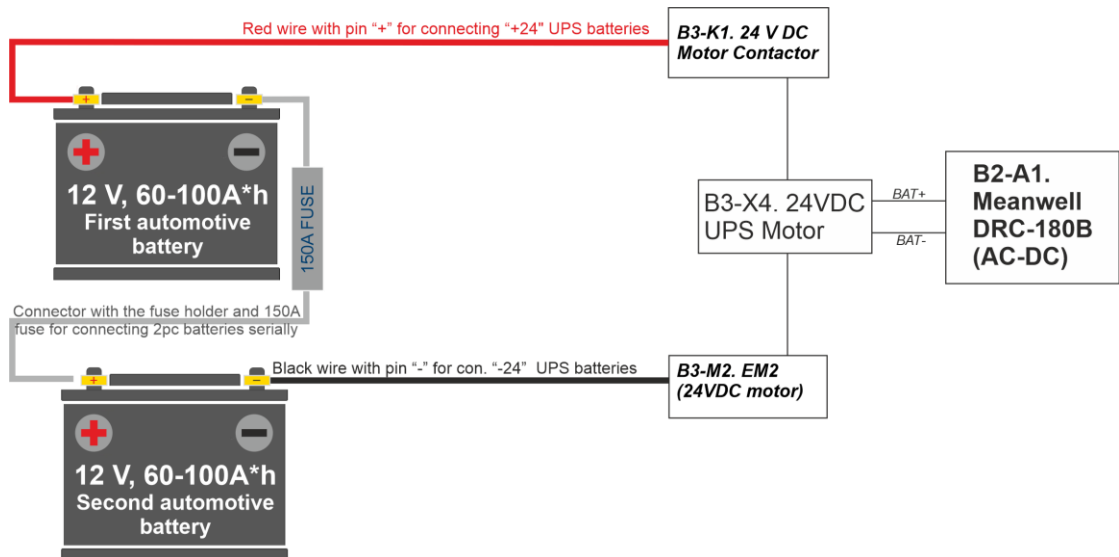

Fig. 21 - Connecting the UPS Function

ROAD BLOCKING SYSTEMS



HIGH SECURITY ROAD BLOCKER

The “-” terminal of the **FIRST** car battery must be connected to the “+” terminal of the **SECOND** car battery in series using the connector with the **WHITE** cable and fuse holder (**FUSE**) from the kit, according to the following wiring diagram.



Attention!

If you are not using the UPS function and are not connecting the batteries, the terminals at the ends of the red and black battery connection cables must be securely insulated to prevent short circuits between each other and against the metal enclosure!

Otherwise, the control unit may become damaged!



If the batteries are connected, the controller monitors their status and charges them with a current of 2A when necessary.

For the UPS function to operate correctly, the batteries must be in good condition, without deep discharge. Their capacity and starting current must be within the normal range.



Attention!

When connecting the UPS, after switching off the main 400/230 VAC power supply, the Road Blocker will not switch to UPS power automatically!

To activate the UPS function, the main power supply must first be switched ON on the control unit (ECU)! In the event of a power outage, the Road Blocker will then automatically switch to UPS power.

HIGH SECURITY ROAD BLOCKER

3.6 Connecting the Traffic Light Option

The traffic light serves as a status indicator for the blocker. It is also connected to the main terminal block B2-X1 of the ECU. The ECU supports connection of both **low-voltage** and **high-voltage** versions of the traffic light. The **low-voltage version** operates at +12V and is switched via an **open collector (open drain)** output. For traffic lights powered by **230V**, separate **relay outputs** are provided on B2-X1.

Table 14 – Designation of Traffic Light Connection Terminals

+12V Traffic Light Connection	Terminal block B2-X1. (Traffic light or RB status out)
Color	
Common +	35. +12V DC
Red	36. Traffic light red / top out (GND)
Green	37. Traffic light green / bottom out (GND)
230V Traffic Light Connection	Terminal block B2-X1. (High voltage traffic light)
Color	
Red	41. Traffic light red out (L) 230V
Green	42. Traffic light green out (L) 230V
Common N	43. Traffic light N
PE	44. PE

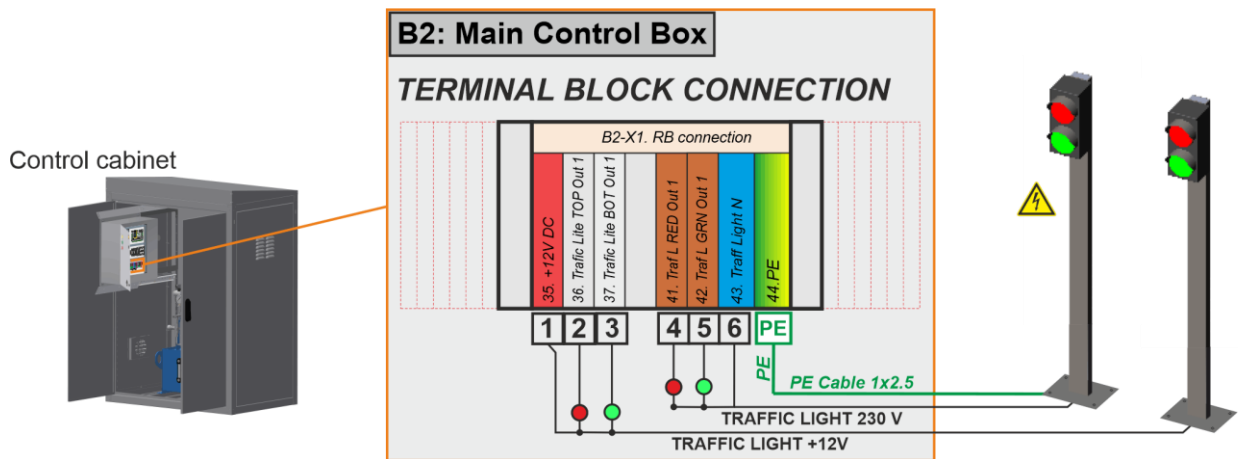

Fig. 22 - Connecting the Traffic Light

3.7 Oil Heating Option in the Hydraulic System - *2.

When the oil heating option is present, a thermostat is installed in the ECU. It ensures the uninterrupted operation of the hydraulic station cabinet and maintains a fixed temperature regime.

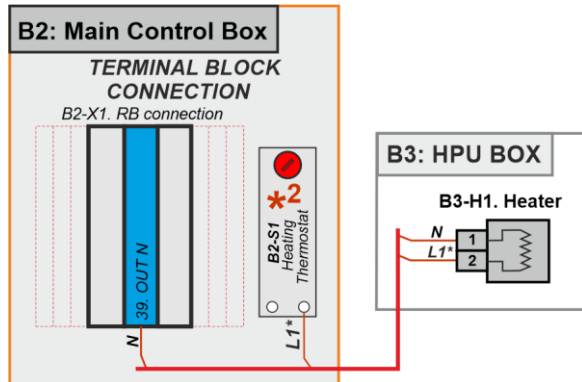

Fig. 23 - Connecting the heating thermostat



Fig. 24 - Thermostat Din Rail Mount NC
Thermostat 15 Degree C (hct hc301 15/5)

3.8 Oil Cooling Option in the Hydraulic System - *7.

The external hydraulic station cooling fan with a cooling thermostat is used when the blockers are installed in hot countries or when the intensity of blocker use is very high. The thermostat is installed in the hydraulic station cabinet and ensures control of the set temperature regime.

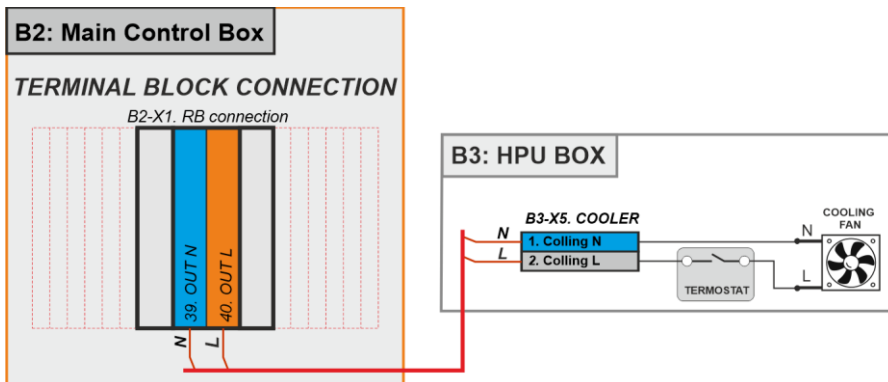

Fig. 25 - Connecting the cooling thermostat



Fig. 26 - Thermostat Din Rail Mount NO
Thermostat 0 to 60 Degree C (GM-KTS011)

3.9 Connection of the Phase Order Relay Option - *4.

The **Phase Order Relay** is designed to detect the correct sequence of phases connected to the hydraulic station motor. If the phases are connected incorrectly, the blocker movement will be reversed, meaning the blocker will lower when it receives the “up” command. One possible reason for the **B2-L3 “Error” indicator** blinking is an incorrect phase order. This issue can be identified using the RB350 controller by navigating to the “ERR” (Error Log) page. If the error “[14] Phase order” is listed, the power supply connection to the ECU should be checked.

HIGH SECURITY ROAD BLOCKER

4. PCB.350 TISO controller as a component of the electronic control unit

4.1 Description of the PCB.350 controller

The PCB350 controller manages the operation of devices by analyzing signals from potential inputs of angle position sensors and wired control panels connected via the RS485 interface. It sets the potential outputs depending on the blocker's status.

The PCB.350 controller allows for the configuration of key parameters for controlling blockers and initiating operation. The front panel of the controller features an OLED display and 4 control buttons for displaying the current status of the controller and the settings menu. The PCB.350 controller is integrated into the electronic control unit. The devices controlled by this unit are TiSO automatic road blockers with an external hydraulic station.

4.2 Purpose of the connectors of the controller PCB350.02

The purpose of the connectors of the PCB350.02 controller when using it for an external hydraulic station in electronic control units RB106 / 107 is shown in Fig.27.

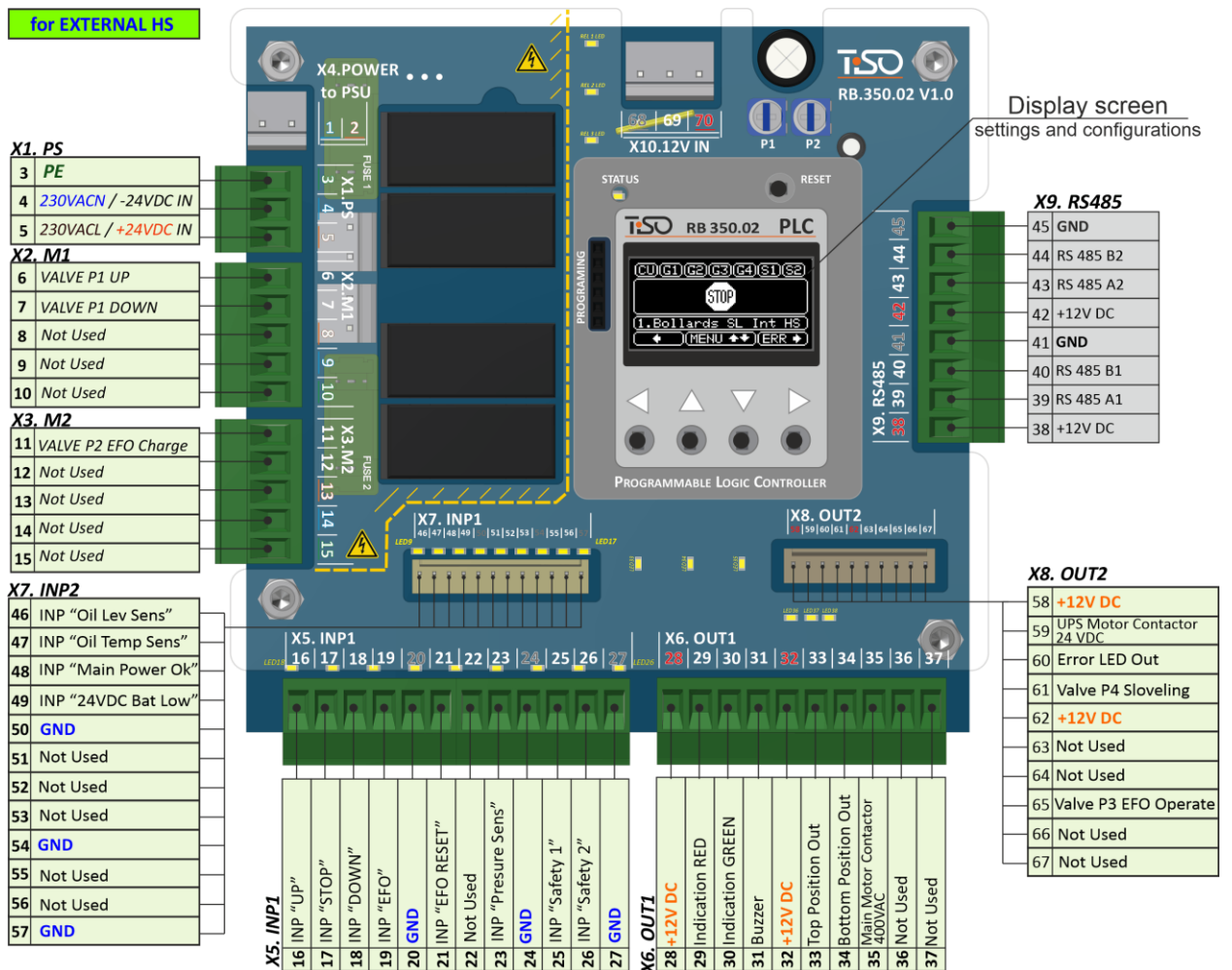

Fig.27 - Purpose of the connectors of the controller PCB.350.02 (when using an external hydraulic station)

HIGH SECURITY ROAD BLOCKER

Table 15 - Purpose of the connectors of the controller PCB350.02

No	Component	Purpose
1	X1 PS Power Supply	Power Supply – Terminal block for connection the controller supply voltage 230VAC or 24VDC
2	Terminal block X2 M1	Terminal block for connection the Hydrostation Valves and Motor Contactor
3	Terminal block X3 M2	Terminal block for connection of the Hydrostation Valves
4	Fuse F1	Fuse 1 – Fuse 6A 250VAC of the X2 M1
5	Fuse F2	Fuse 2 – Fuse 6A 250VAC of the X3 M2
6	Terminal block C1	C1 – Not Used in this configuration
7	Terminal block C2	Not Used in this configuration
8	Terminal block X5 INP1	Inputs 1 – Terminal block for connection of the Road Blocker control inputs, sensors and auxiliary devices
9	Terminal block X6 OUT1	Outputs 1 – Terminal block for connection of the Road Blocker actuating devices and auxiliary devices
10	Terminal block X7 INP2	Inputs 2 – Terminal block for connection of the Road Blocker control inputs, sensors and auxiliary devices
11	Terminal block X8 OUT2	Outputs 2 – Terminal block for connection of the Road Blocker actuating devices and auxiliary devices
12	Terminal block X9 RS485	Interface RS485 – Terminal block for connection of the Road Blocker wired remote control panel and angular position sensors
13	Terminal block X4 230V TO PSU	Not Used in this configuration
14	Terminal block X10. 12V from PSU	12V DC from Power Supply Unit – Terminal block for connection of the power supply unit voltage 12VDC to the controller PCB350.02
15	Switch SW1- SW8	Switch 1-8 – Switch of the control unit mode and configuration parameter setting
16	Indicators LED1-LED8	Displays of mode and configuration parameters
17	Indicators LED9-LED17	Displays of the Road Blocker2 input INP2 status
18	Indicators LED18-LED26	Displays of the Road Blocker1 input INP1 status
19	Indicators LED27-LED32	Displays of the Road Blocker2 output OUT2 status
20	Indicators LED33-LED38	Displays of the Road Blocker1 output OUT1 status

4.3 Display for viewing settings and configurations of the PCB 350 controller

1) Loading screen

Then the device is turned on or after it is restarted, the logo and software version will be displayed on the screen for one second.



HIGH SECURITY ROAD BLOCKER

2) Start screen

The start screen on the PCB.350.02 controller display consists of four main fields (Fig.28):

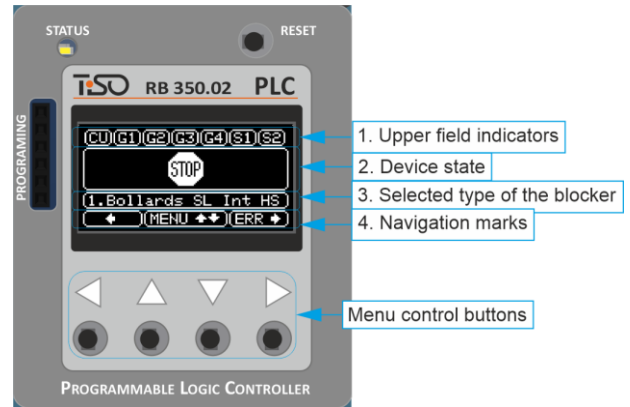

Fig. 28 – Start screen of the controller display PCB.350.02

Table 16– Main fields of the start screen on the PCB350 controller display

Field name	Description	Label
1. Upper field indicators	- indicator, which is responsible for communication with the remote control	
	- the indicator responsible for communication with the 1th inclinometer.	
	- the indicator responsible for communication with the 2th inclinometer.	
	- the indicator responsible for communication with the 3th inclinometer.	
	- the indicator responsible for communication with the 4th inclinometer.	
	- active induction loop indicator 1.1 or 1.2.	
	- active induction loop indicator 2.1 or 2.2.	
	If there is no communication with the remote control, protractors or inactive induction loops, then the inscription in the indicator is absent.	
2. Device state	The number and current state of blockers is displayed in the center of the start screen. The number of the blocker is displayed in the field next to the state sign. If in item "9. Number of blocker" 1 device is selected, then only one state icon will be shown on the display.	
3. Selected type of the blocker	This field displays the name of the blocker whose logic is currently being processed.	
4. Navigation marks	• Switching to the <u>list of statuses and states of inputs/outputs</u> .	
	• Switching to the <u>settings menu</u> is carried out by long pressing the buttons or .	
	• Switching to the <u>list of errors</u> is carried out by long pressing the button .	

3) Setup menu

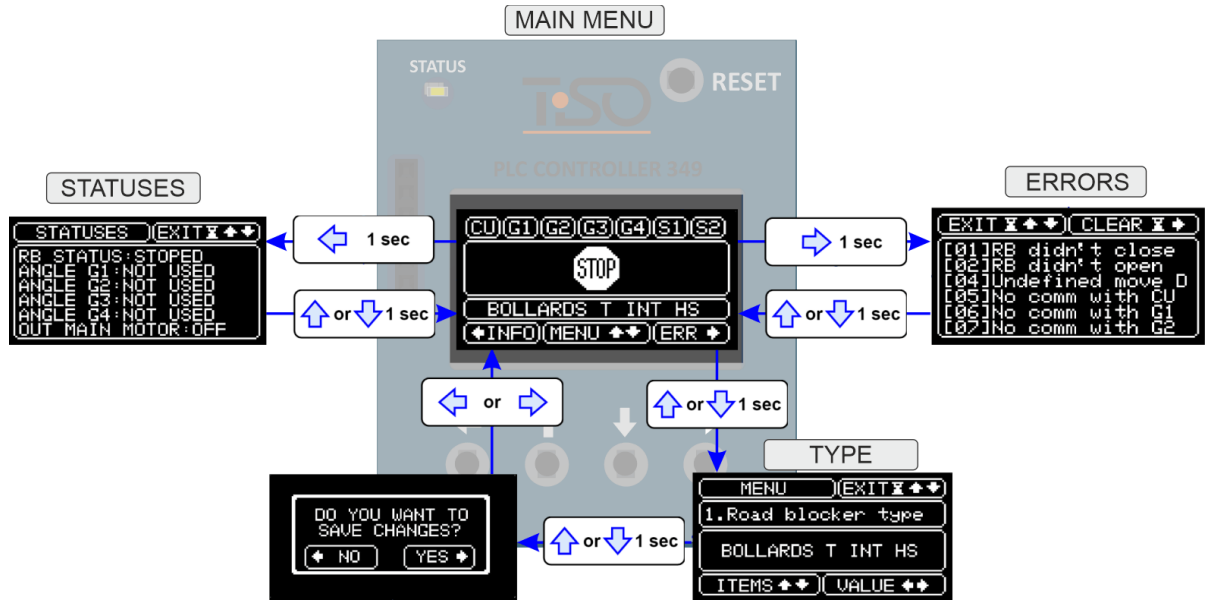

Fig. 29 – Diagram of entering and exiting the settings menu.

The settings menu is intended for changing the device parameters. It is quite simple and consists of three main parts:

“Item name ” (1)

The number and name of the settings item are displayed in the first field. The text is displayed as a moving line, if the name of the item is longer than the width of the screen.

“Mode of operation or value of the item ” (2)

The name of the mode or value is displayed in the second field. If the parameter is set as a value (a), then fields with its maximum (b) and minimum (c) possible values are displayed on the screen.

“Navigation inscriptions” (3)

The fields are intended for navigation highlighted above and below. In these fields there are inscriptions and graphic symbols that explain which function this or that button corresponds to.

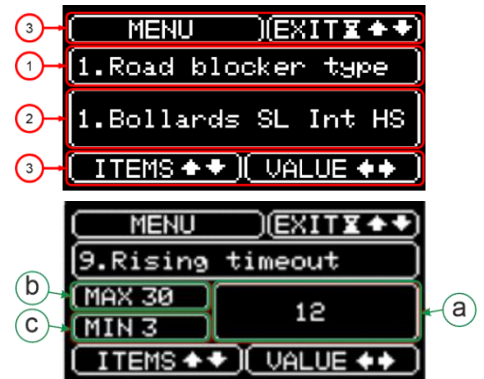



Table 17 - Navigation Fields

<ul style="list-style-type: none"> Switching between settings items is carried out with a short press of the buttons and . 	
<ul style="list-style-type: none"> Changing the parameter itself is carried out by pressing the buttons and . Increasing or decreasing numerical parameters can be accelerated by holding down the buttons. 	
<ul style="list-style-type: none"> To exit the settings to the start screen, you need to press and hold the button for 1 second or . 	
<p>After a long press on the buttons or , a screen will appear asking "Do you want to save the changes?". After the user clicks "yes" or "no", the program will return to the start screen.</p>	

ROAD BLOCKING SYSTEMS









If a newer version of the software has been downloaded to the controller, then for the correct operation of the device, the settings should be reset to the factory settings. To do this, you need to find an item «22. Reset to factory settings» in the menu. Then press and hold the button  for 1 second. In the window that appeared on the screen, you need to confirm the action by pressing the button . After these actions, it must be configured for the desired type of blocker.

For operating settings, parameters, and a description of possible errors of the PCB350.02 controller, refer to Tables 3 and 5 in the device setup manual «PCB 350.02 DEVICE SETUP GUIDE v.1.5.0»

5. SYSTEM OPERATION CHECK

After ensuring that all device components are connected properly, you can begin the verification and setup process.

1. The first step is to check the device type in the PCB350 controller settings. Open the ECU and access the PCB350 controller. On the start screen of the display, there is a dedicated field №3 called "Selected Blocker Type". The operation of the entire system depends on the selected type. There are several types available: "BLOCKER HS EXT HS", "CYCLOPE HS EXT HS", and "SPEEDBUMP HS EXT HS". If a different blocker type is displayed, it should be changed to the correct one. For more details on changing the blocker type and other settings, refer to Tables 3 and 5 of the. «PCB 350.02 DEVICE SETUP GUIDE v.1.5.0».
2. Now, you can issue a command for raising or lowering the device from the control panel. If everything is connected correctly, the device will perform the corresponding movement.
3. The next step is the calibration of the device's end positions. The calibration process is enabled through the settings menu. To calibrate the device, perform the following actions:
 - Press and hold the button  or  to enter the settings menu.
 - Navigate to the "2. Angle sensor calibration" option using a short press of the button .
 - To start the calibration process, press the button . This will initiate the automatic calibration process.

During calibration, the controller will raise and lower the device for the maximum lifting and lowering time. After completing this process, the display will show "Calibration done", indicating successful calibration.

The detailed calibration process of the device is shown in Fig. 30.



- If, after pressing the button  the blocker does not start moving and the display shows "Check ERR and repeat", check the connection of the DI-602 angle position sensor.
- If, after completing the calibration process, the display shows "Check ERR and repeat", go to the ERR section and check which specific issue occurred during calibration.
- For more information on the calibration process and possible errors, refer to the "PCB 350.02 DEVICE SETUP GUIDE v.1.5.0".

HIGH SECURITY ROAD BLOCKER

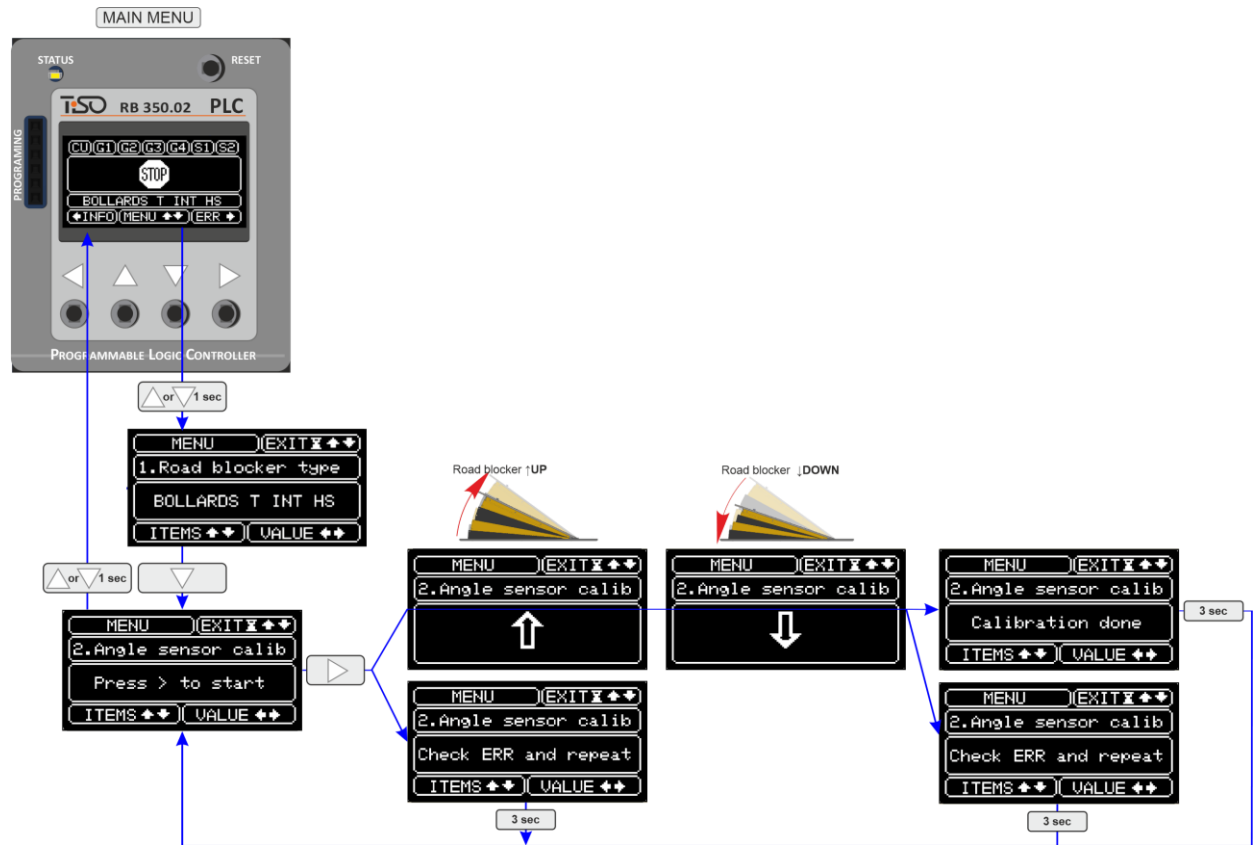

Fig.30 - Device Calibration Process Diagram

- The blocker can be controlled either via the control panel or through potential inputs.

HIGH SECURITY ROAD BLOCKER

6. POSSIBLE MALFUNCTIONS AND TROUBLESHOOTING METHODS

After the initial connection or after a certain period of operation, some malfunctions or errors may occur. These can range from minor issues such as “**traffic light not working**” to more serious faults that affect the proper functioning of the blocker system.

Table 18 provides a list of the most common malfunctions and possible solutions.

Table 18

№	Malfunction	Possible Cause	Solution	"ERROR" Indicator
1	Road Blocker does not raise or lower when receiving Raise/Lower commands.	Hydraulic hoses from the hydraulic station (HS) to the blocker are not connected or connected incorrectly.	Check and correctly connect the hydraulic hoses according to the instructions.	-
		Insufficient oil level in the hydraulic station. If the oil level sensor option is available, it can be checked.	Check the oil level in the hydraulic station. Refill as needed.	Blinking (if oil level sensor B3-S2 is present).
		Angle position sensors DI-602 are not calibrated.	Calibrate the DI-602 sensor according to Step 3 in Section 5 “ SYSTEM OPERATION CHECK ”.	Blinking (if no connection).
2	Blocker moves in the opposite direction	Incorrect phase order connection (L1, L2, L3) of the 3-phase power supply.	Swap two of the phases (e.g., L1 and L2) as described in Section 3.1 “ Connecting the Electronic Control Unit to the Power Supply ”.	Blinking (if phase order relay B2-A7 or B2-A6 is present).
3	The hydraulic station keeps running for a long time after the blocker reaches the upper or lower position.	Angle position sensors DI-602 are not calibrated.	Calibrate the DI-602 sensor according to Step 3 in Section 5 “ SYSTEM OPERATION CHECK ”.	Blinking (if no connection).
		Incorrect blocker type or quantity selected.	Check the selected blocker type and related parameters in the PCB350 settings menu. See “ PCB 350.02 DEVICE SETUP GUIDE v.1.5.0 ” for details.	-

HIGH SECURITY ROAD BLOCKER

Continuation of the table 18

4	The blocker's light or sound signal is not working	The light or sound signaling device of the blocker is not connected or is connected incorrectly.	Check the connection according to the diagrams in Annex 1 and Annex 2 , or refer to sections " 3.2 Connecting the Road blocker to the ECU " and " 3.6 Connecting the traffic light. "	-
		Incorrect indication mode is enabled on the PCB350 controller.	Change the indication or status output mode of the controller. This can be done in the settings menu of the PCB350 controller . For more details, see " PCB 350.02 DEVICE SETUP GUIDE v.1.5.0 ".	-

Annex 1. - Wiring diagram of the Road Blockers to control unit RB106+EFO rev. 1.4

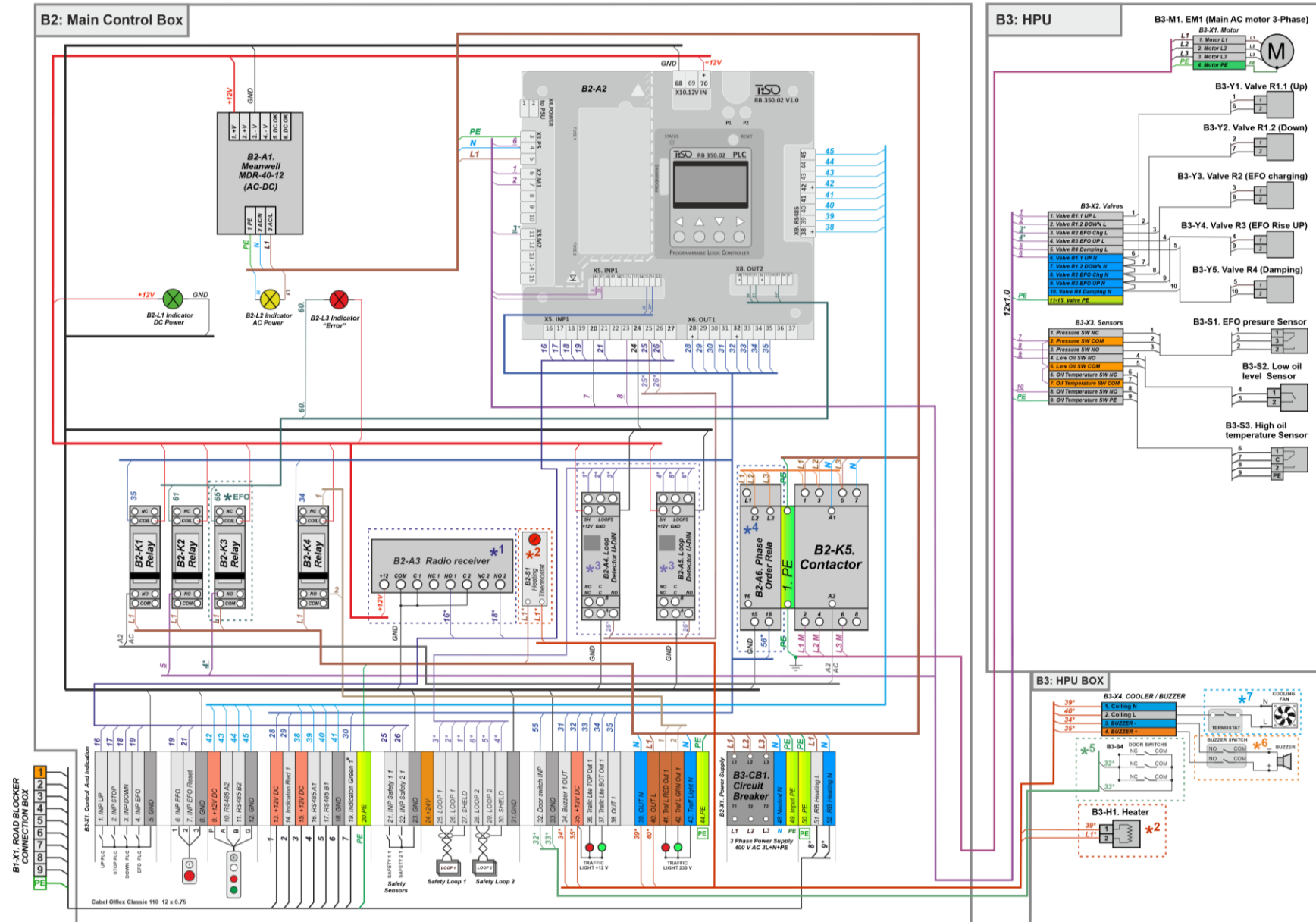

Annex 2. - Wiring diagram of the Road Blockers to control unit RB107+UPS+EFO rev. 1.4

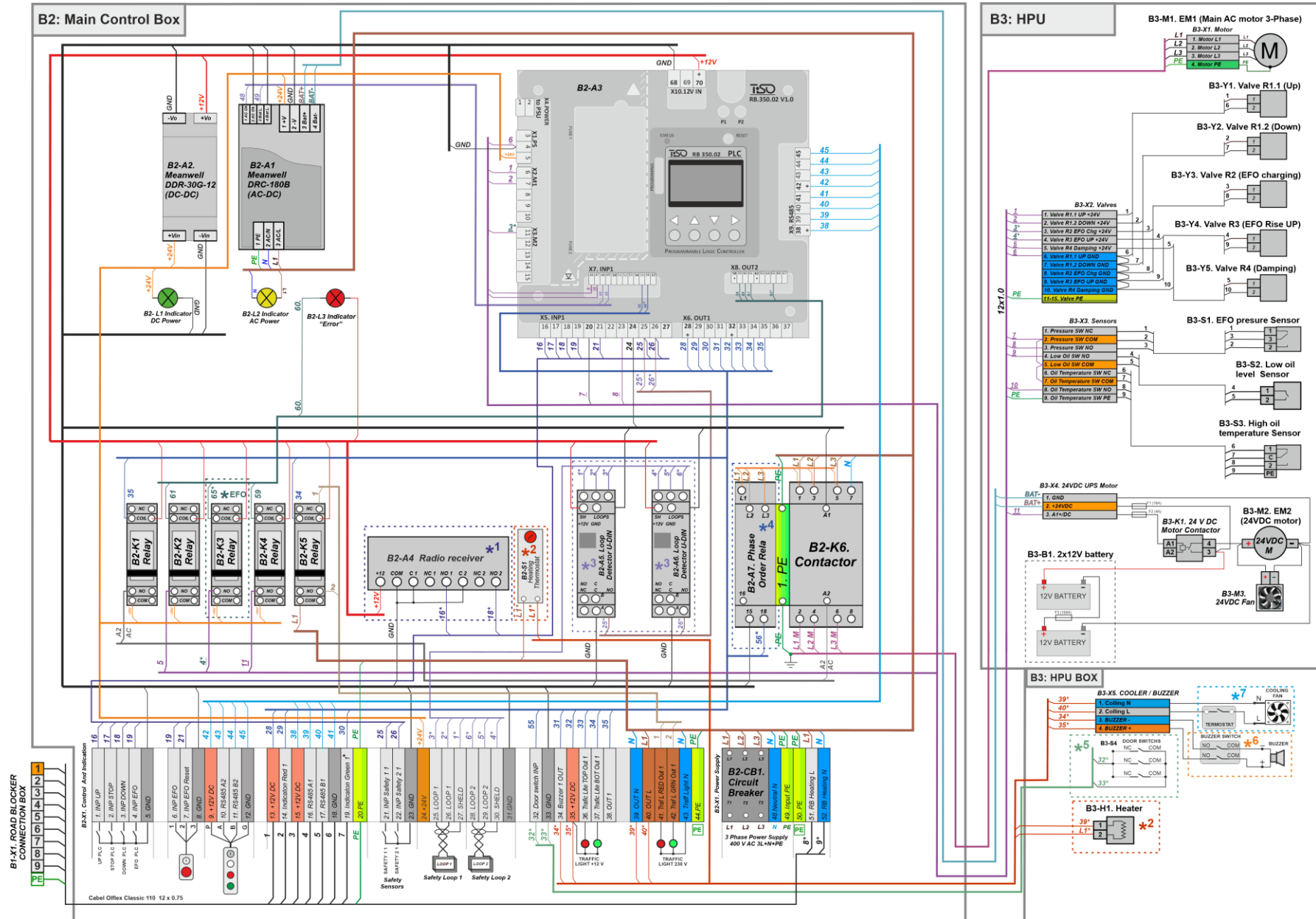

Annex 3. - Wiring diagram of the Road Blockers to control unit RB106.1+EFO rev. 1.4

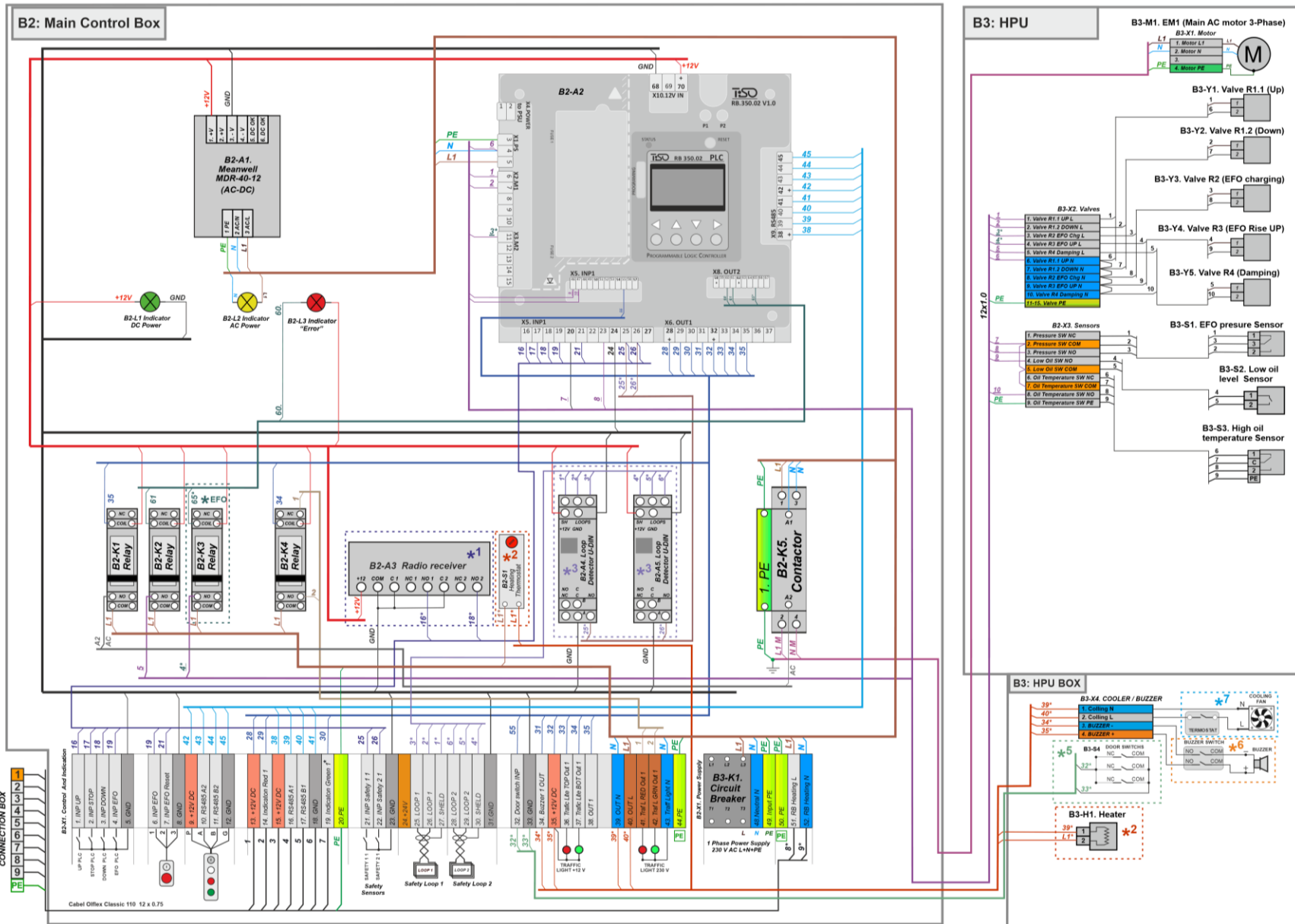

Annex 4. – Wiring diagram of the Road Blockers to control unit RB107.1+UPS+EFO rev. 1.4

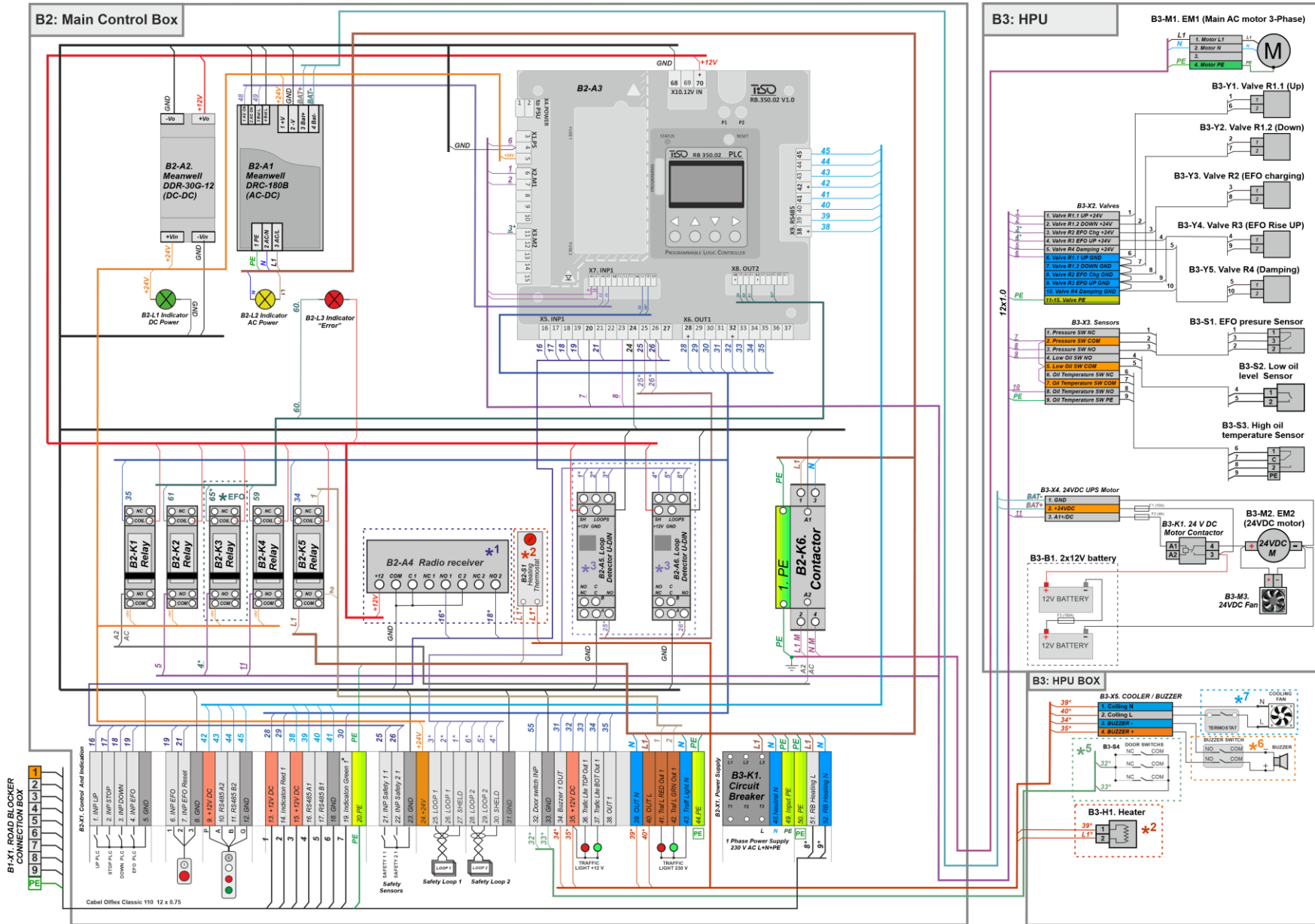

Annex 5. – Diagram of connection of the Road Blockers to control unit RB106 / RB107 / RB106.1 / RB107.1

TERMINAL CONNECTORS DESCRIPTION

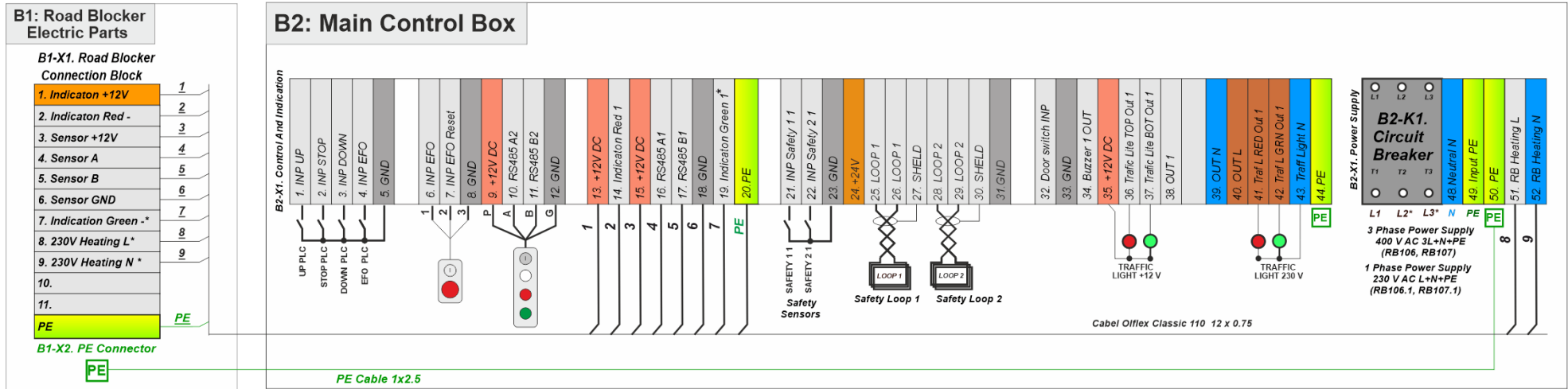

*L2, L3 are used only in control units RB106 and RB107