

BOOM BARRIER

Installation and Operation Manual

Revision 1.3

2026

Original guide

OPERATION MANUAL. PART I

AUTOMATIC BOOM BARRIER WITH BMDrive MECHANISM OPTIMUS 50 BM series of RB392-05

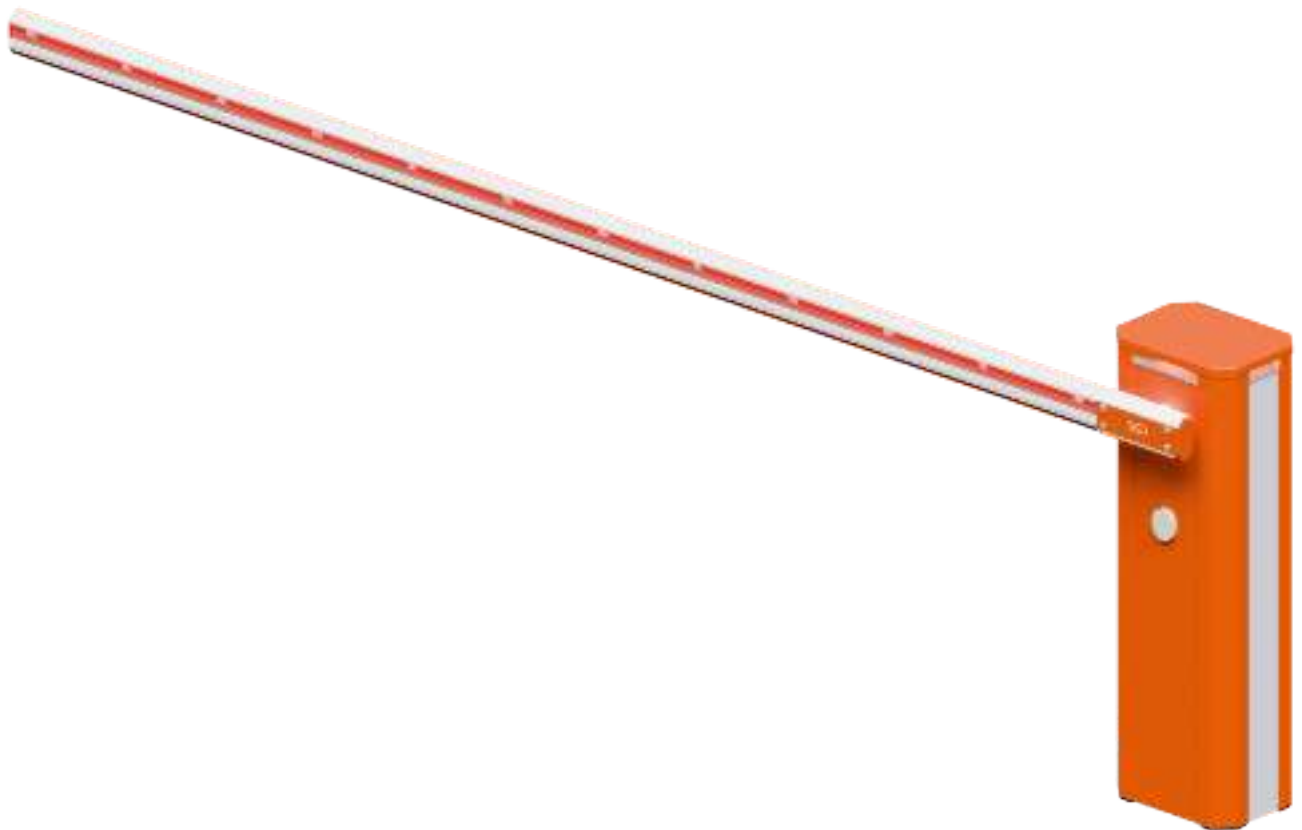

ROAD BLOCKING SYSTEMS



Office and Production site:
14 Promyslova str., 02088, Kyiv, Ukraine,
E-mail: sales@tiso.global

Tel.: +380 (44) 291-21-11
Fax: +380 (44) 291-21-02
www.tiso.global

Page
-1-

Size A4

BOOM BARRIER

Contents:

DECLARATION OF CONFORMITY OF EQUIPMENT	3
1. General Guidelines.....	4
1.1 Instruction for installers.....	4
1.2 Instruction for users.....	5
2. Description	6
3. Product Purpose	6
4. Technical Specifications.....	7
4.1 Technical features of boom barrier.....	7
4.2 Overall dimensions.....	8
5. Product specification	9
5.1 Scope of Delivery.....	9
5.2 Key elements of boom barrier.....	9
5.3 Boom Barrier mechanism design.....	10
6. Installation of boom barrier.....	11
6.1 Preliminary check.....	11
6.2 Tools	11
6.3 Preparation of bottom plate and installation of barrier cabinet.....	12
6.4 Barrier arm mounting.....	13
6.4.1 Barrier arm installation.....	13
6.4.2 Fast adjusting process.....	14
6.4.3 Arm balancing.....	15
6.4.4 Arm position adjustment.....	16
6.5 Manual control	17
6.6 Versions of Boom barrier.....	18
6.7 Changing the direction of the barrier arm.....	19
7. Connection of boom barrier utilities.....	20
7.1 Main connection of boom barrier.....	20
7.2 Controller.....	21
7.3 Connection of barrier arm lighting.....	22
7.4 Connection of barrier arm bumper lighting.....	23
7.5 Installation and connection of IR barriers (safety sensors).....	24
7.6 Installation of induction loops.....	24
8. Precommissioning.....	26
8.1 Preparation for precommissioning.....	26
8.2 Precommissioning.....	26
8.3 Controlling the operation of boom barrier.....	26
9. Routine maintenance.....	27
9.1 Spring replacing.....	27
9.2 Possible malfunctions	28
10. Boom barrier operation regulations.....	29
10.1 Rules of operations	29
10.2 Equipment maintenance.....	29
10.3 Safety regulations.....	30
11. Notes.....	31



- This Manual is an integral part of the product and shall be handed over to the customer. The Manual shall be kept for future use and to be consulted, if appropriate.
- If the Boom barrier is resold, handed over to another owner or transported to another place, make sure that this manual is enclosed to the product to be used by new owner and/or maintenance staff during installation and/or operation.



The following abbreviations are used in this Manual:

- OM-Operation Manual;
- ACS - access control system;
- IR - infrared safety sensors;
- M - Maintenance
- R.s.l - Road surface level (reference point + 0.000).

ROAD BLOCKING SYSTEMS



Office and Production site:
14 Promyslova str., 02088, Kyiv, Ukraine,
E-mail: sales@tiso.global

Tel.: +380 (44) 291-21-11
Fax: +380 (44) 291-21-02
www.tiso.global

BOOM BARRIER

1. General safety provisions



The Manual should be scrutinized prior to the equipment installation and operation to ensure the human safety. Safety is not ensured in case of improper operation or use.

- TiSO Company ensures its best effort for guarantee and correctness of this Manual and reflecting material changes in the design. However, a policy of continuous improvement can lead to insignificant differences between the equipment supplied and the description in this document.
- The Manual to be kept for future use.
- Do not allow children and unauthorized persons to stay near operating equipment. The manufacturer shall bear no responsibility for violation of safety rules.
- Any actions that are not explicitly listed in these instructions shall be prohibited.
- Safety devices shall protect potentially hazardous areas.



- **Personnel involved in maintenance of existing electrical installations or commissioning, electrical installation, repair work, maintenance and installation shall be trained to work with this model of the device! Training shall be carried out at the manufacturer's representatives' or at the manufacturers' of the product.**
- **In the case of violation of the operating rules and the requirements of the operational documentation, the boom barrier may pose no hazard to life and health by virtue of high voltage and moving parts of the product!**
- **Transportation of the product shall be ensured only with the barrier arm removed!**

1.1 Instructions for installers:

1. For your safety, follow the installation instructions;
2. The product shall be installed in accordance with applicable regulations and rules, in compliance with safety precautions during installation work;
3. Installation of the equipment shall be carried out with the power supply disconnected;
4. Packaging materials shall be disposed in accordance with applicable standards;
5. Strictly observe the sequence of operations for assembling the boom barrier specified in the instruction;



- **It is forbidden to make changes to the arrangement of equipment and use of materials and components that are not included in scope of delivery and are not provided for in this Manual.**
- **Do not install this equipment during a lightning storm, heavy rain or snow, in an explosive atmosphere and in poor visibility. Mounting zone is equipped according to the current standards.**
- **Boom barrier installation, connection and commissioning works shall be performed by specialists of the appropriate qualification.**

6. If faults or defects are detected, contact the supplier's service service.
7. The installer shall provide the user with the necessary information on the operation of the system in manual mode in case of an emergency.
8. Before handing over the product to the end user, check consistency of product indicators. Make sure that the automation, security and unlocking of drive configured correctly.
9. Appropriate warning signs, operating in the territory of the country, shall be placed on the section of traffic regulated by boom barrier!

The manufacturer is not responsible for the operation of equipment in the following cases:

- non-compliance with the installation technology,
- use of non-standard materials and components,
- performance of work by unqualified personnel,
- manufacturer is not responsible for the safety measures when installing the equipment by personnel not involved in the company service department.

ROAD BLOCKING SYSTEMS



BOOM BARRIER

1.2 Instructions for users:

1. For your safety, follow the installation instructions;
2. It is forbidden to make changes to the arrangement of equipment;
3. Strictly observe the sequence of operations for assembling the boom barrier specified in the Manual;
4. Do not attempt to repair or configure the boom barrier yourself, please contact the appropriate service. Breaking of seals cancels the guarantee obligations of the manufacturer.
5. The control points (control panels) of the boom barrier shall be inaccessible to outsiders.
6. TiSO Company is not responsible for incorrect operation of the equipment, violation by user of security measures;



- **The boom barrier must be installed, precommissioned and serviced by the certified professionals having the relevant qualification and being familiar with Manuals and product documentation such as:**
 - Installation and operation manual (Part I, Part II);
 - Technical passport;
 - Instruction manuals for components.
- **Technical inspections, maintenance, adjustment and repair shall be performed only when the boom barrier is deenergized.**
- **The product designed and manufactured in accordance with directives of the European Union, shall be marked according to CE standards.**

BOOM BARRIER

2.

Description

2.1 Electro-mechanical boom barrier is intended for arrangement and control of vehicle passageway width up to 5 m.

2.2 Boom barrier has a reliable simple structure, the main elements of which are a stand with a power-operated mechanism, an barrier arm and an electronic control unit. Boom barrier is balanced by tension/compression of spring and depends on the arm length and accessories installed on it.

2.3 The barrier may be operated from:

- wired or wireless remote control;
- automatic access control system (access cards, exit buttons);
- manual (in case of power failure the boom barrier can be operated manually)

2.4 Coating - black and orange paint ;

2.5 A wide range of accessories is available for convenient use:

- LED lighting of Barrier arm
- IR barriers (safety sensors)
- induction loops
- arm support post
- reflective stickers for arms
- traffic light, etc.

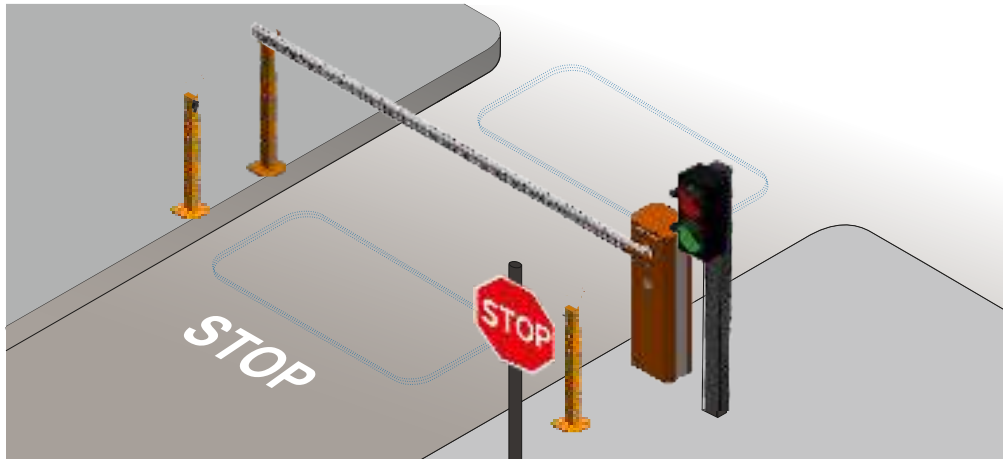

3.

Product Purpose

3.1 The electromechanical barrier is intended to restrict access to territory with high traffic intensity and width of passage up to 5 meters. The barrier is used at state, commercial and private facilities to restrict unauthorized entry and exit of vehicles, to regulate and arrange traffic of road transport at facilities and adjacent territories. These can be automated parking zones, customs terminals, etc.

3.2 The Boom Barriers are recommended for passenger transport facilities, in the driveway to sports facilities and governmental facilities, to be installed in front of shops, hotels, shopping malls and office centers, health care facilities, at the approaches to cottages and cottage settlements, at central urban and historical sites, industrial and special facilities.

3.3 The Boom Barriers can be installed along with other traffic control and unauthorized access prevention equipment.

3.4 By impact of environmental factors the Boom Barrier complies with EN 300 019-1-4 and is designed for outdoor operation in temperate conditions with permissible ambient temperature - 10°C to +40°C.



OFFICE BUILDINGS



PLANTS



SPORTS AND LEISURE CENTERS



HAULAGE COMPANIES



PARKING LOTS

ROAD BLOCKING SYSTEMS



Office and Production site:
14 Promyslova str., 02088, Kyiv, Ukraine,
E-mail: sales@tiso.global

Tel.: +380 (44) 291-21-11
Fax: +380 (44) 291-21-02
www.tiso.global

BOOM BARRIER

4. Technical Specifications

4.1 Technical features of boom barrier

Table 1- Technical features of boom barriers

Boom barrier	Optimus 50 BM			
Series	RB392-05			
Installation type	BMDrive24V BMDrive (BLDC)			
Operation mode	left/right version			
Arm length	2 – 5 m			
Overall dimensions of Boom barrier with arm	348x2050x1050	348x3050x1050	348x4050x1050	348x5050x1050
Dimensions of cabinet	255 x 340 x 1050 mm			
Barrier arm	rectangular section 45,5x80 mm			
Barrier arm height position	850 mm			
Weight	45 kg			
Power consumption	240 W			
Operating voltage	230VAC (186-240VAC); 50/60 Hz			
Opening / Closing time	3 – 5 sec			
Protection level	IP 54			
Temperature range	standard - 20° C / +50 ° C			
Temperature range**	optional - 40° C / +60 ° C			
Noise level	< 70 dB			
Operation frequency	300 cycles/hour			
Usage rate	90%			
MCBF	3 000 000 cycles			
MTTR	< 25 min			
Torque	320 N m			
Cabinet material	galvanized steel with powder coating			
Arm barrier material	powder coated aluminium			
LED indication	All sided RG light indication (in cabinet) - standart arm lighting RG - optional			
Raised position locking	DeadLock®			
Manual operation with power off	manual release mechanical device			

* Technical features can be changed without prior notice;

** For temperatures below -20 °C heating system to be used / for temperatures above +50 °C cooling system to be used

Table 2- Supplementaries for boom barriers

Additional options:	
Arm support post	+
Reflective stickers for arm	+
Bottom plate	+
IR barrier (safety sensors)	+
Set of posts for IR barriers	+
Arm lighting (RGB)	+
Induction loop kit	+
Traffic light	+
Post for traffic light	+
Cooling system	+
Heating system	+
Remote control industrial IP54	+
Additional remote keyfob	+

ROAD BLOCKING SYSTEMS



Office and Production site:
14 Promyslova str., 02088, Kyiv, Ukraine,
E-mail: sales@tiso.global

Tel.: +380 (44) 291-21-11
Fax: +380 (44) 291-21-02
www.tiso.global

BOOM BARRIER

4.2 Overall dimensions (for road width from 2 m to 5 m)

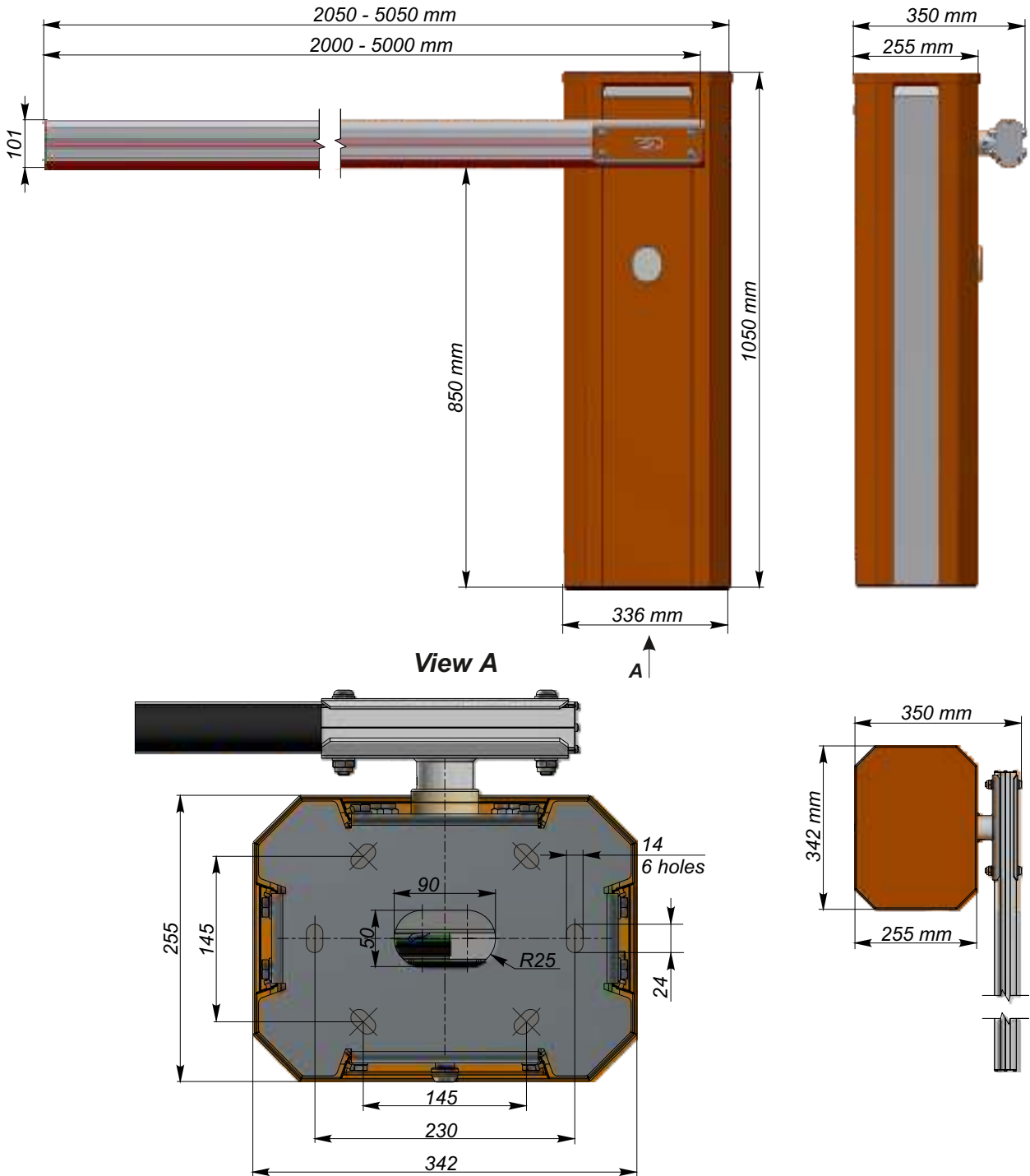

ROAD BLOCKING SYSTEMS



Office and Production site:
14 Promyslova str., 02088, Kyiv, Ukraine,
E-mail: sales@tiso.global

Tel.: +380 (44) 291-21-11
Fax: +380 (44) 291-21-02
www.tiso.global

BOOM BARRIER

5. Product specification

5.1 Scope of Delivery:

After the Boom Barrier is received it is to be unpacked and inspected to be sure that the Boom Barrier is not damaged. If any damage is found then the Road Barrier supplier to be contacted.

Scope of delivery for Boom Barrier specified in Table below:

Table 3- Scope of delivery

Item	Quantity
Barrier cabinet with built-in control unit	1 pc
Radio remote control	2 pc
Key for door	1 set
Arm holder fixing plate	1 pc
Arm plate with logo	1 pc
Arm padding	2 pc
Screw M10x75 A2	4 pc
Self locking nut M10 A2	4 pc
Washer M10 A2	8 pc

5.2 Key elements of boom barrier:

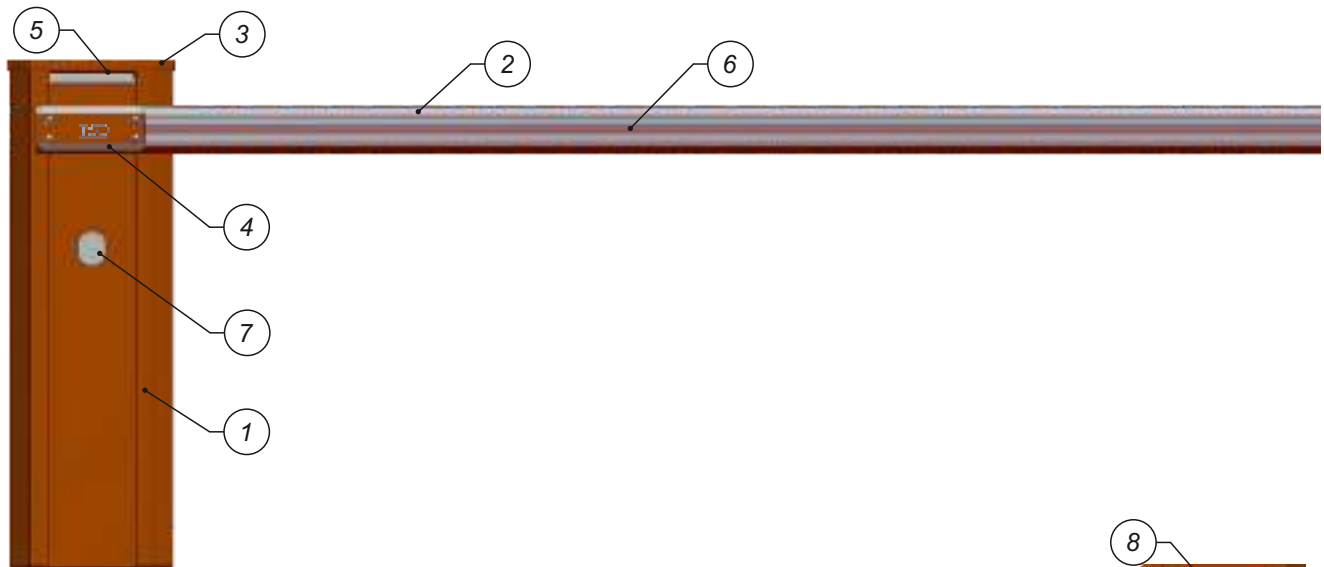

Legend:

1. Boom barrier
2. Arm
3. Cabinet lid
4. Bracket for arm fixation
5. RGB cabinet indication
6. RGB arm lighting (optional)
7. Remote control receiver
8. Lock
9. Door

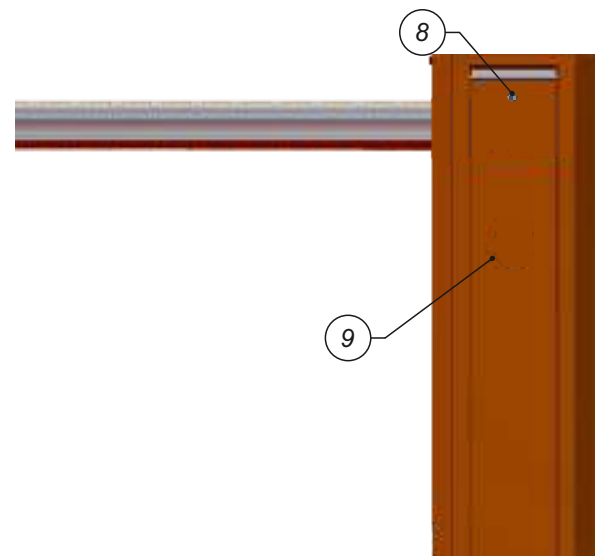

* boom barrier from side of protected area

ROAD BLOCKING SYSTEMS



Office and Production site:
14 Promyslova str., 02088, Kyiv, Ukraine,
E-mail: sales@tiso.global

Tel.: +380 (44) 291-21-11
Fax: +380 (44) 291-21-02
www.tiso.global

BOOM BARRIER

5.3 Boom Barrier mechanism design

The picture below shows the structure of left-hand boom barrier mechanism, barrier arm is in the vertical position, the sector of the mechanism is in the lower position, the spring is in the compressed state.

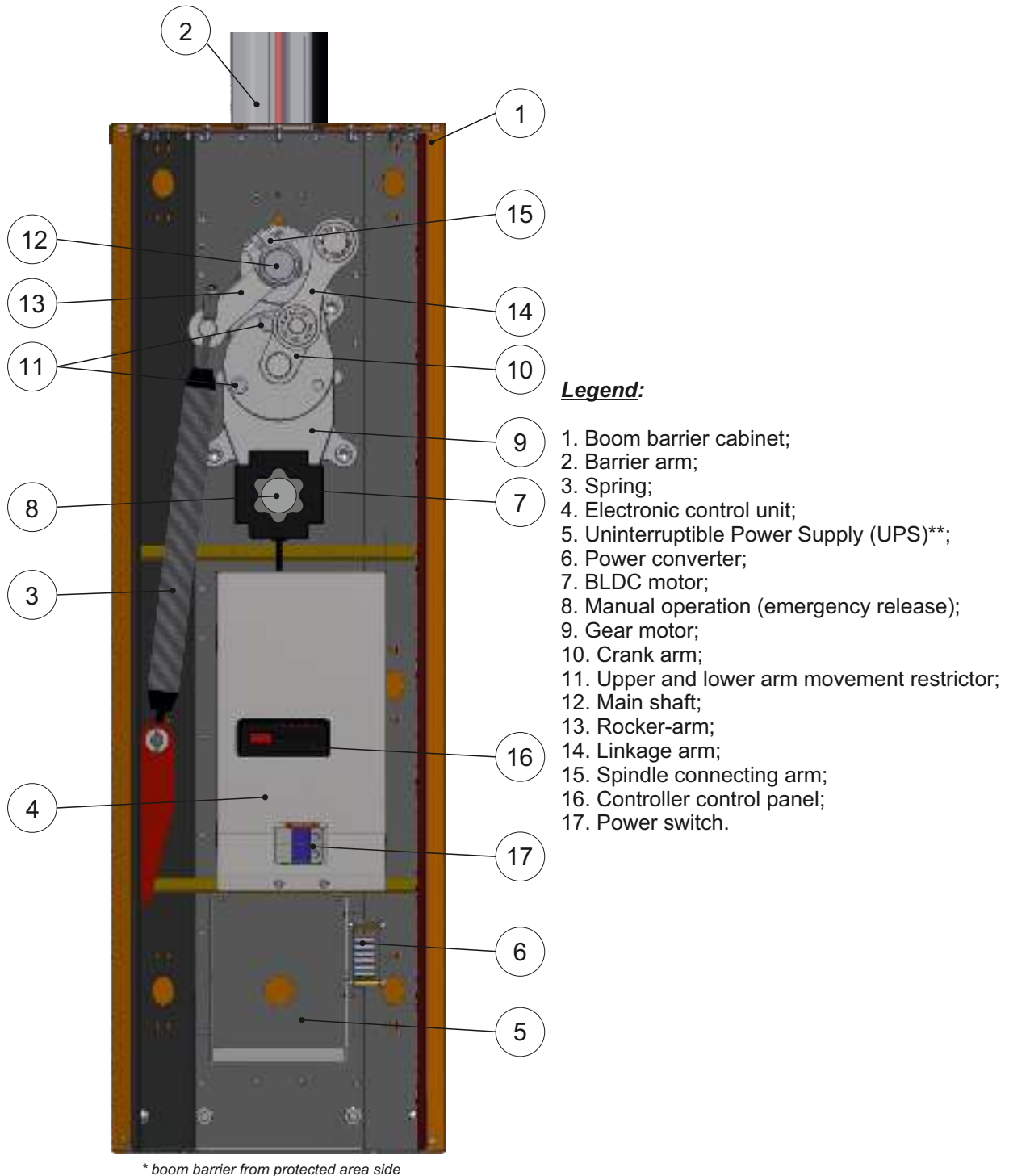

ROAD BLOCKING SYSTEMS



Office and Production site:
14 Promyslova str., 02088, Kyiv, Ukraine,
E-mail: sales@tiso.global

Tel.: +380 (44) 291-21-11
Fax: +380 (44) 291-21-02
www.tiso.global

BOOM BARRIER

6. Installation of boom barrier



- Arrangement of installation site must comply with requirements of the applicable regulations and standards.
- Installation area shall be fenced along perimeter with temporary security fencing or caution tape at the distance of 3 meters from the installation site.
- The appropriate warning signs ISO 7010:2011 shall be installed in front of the installation site.
- Keep outsiders away from the installation site!
- Safety regulations must be observed during installation!

6.1 Preliminary check

Make sure that the following conditions are met to ensure safe and reliable operation of the Boom Barrier:

- Make sure that there are no underground utilities at the installation site!
- The boom should not be in contact with foreign objects (e.g. tree branches) along the entire movement and should move at least 2 m apart overhead power transmission lines.
- The installation site soil should provide high stability of the base plate.
- No underground pipes and/or cables to be available within the excavation area for the base plate installation.
- If there is a risk of damage of the Boom Barrier body by passing vehicles, then the required precautionary measures to be taken, if applicable, to protect it from impacts.
- The Boom Barrier rack to be securely grounded to ensure electrical safety.
- The Boom Barrier installation requires preliminary pulling of electric cables and, if necessary, laying of the base plate.

6.2 Tools

Prior to installation make sure of availability of all necessary tools and materials, ensuring the system installation in full accordance with the applicable safety regulations.

The minimum kit of the required installation tools is shown in Figure below.



Note to boom barrier installation:

The barrier may be used exclusively for the passage of vehicles. Pedestrians shall not pass under a moving arm. A passage suitable for pedestrians should be provided. This passage shall be indicated by a special sign;

The cabinet door shall be located on the inside of the territory. If you are in the centre of the passageway, turn towards the outside:

- if the cabinet is on the left, it means it is a left version of boom-barrier,
- if the cabinet is on the right, it is a right version of boom-barrier.

BOOM BARRIER

6.3 Preparation of bottom plate and installation of barrier cabinet



The ground on the installation site shall be sufficiently stable for installation of boom barrier. If the stability of the soil is unsatisfactory, increase the depth of pit as recommended by the specialists. It is recommended to install barrier cabinet in such a way that cabinet door to be opened from the protected area.

There are two ways to mount a barrier cabinet on the site:

Option 1 -Cabinet fastening

1) Dig the ground for concrete base, prepare the corrugated hoses necessary for making connections for the subsequent routing of cables in them (the required number of channels depends on the type of installation and the connected accessories).

2) The barrier cabinet is fixed to the foundation by means of anchor bolts. The depth of concreting depends on the softness of soil and on the depth of soil freezing (200–500 mm).

3) The cabinet to be oriented correctly, and levelled by means of builder's level, anchor (M12x165) holes for high performance concrete expansion to be marked and drilled along the perimeter.

4) The Bottom plate to be installed and anchor nuts to be screwed.

5) The Cabinet to be installed and bolts to be installed and nuts to be tightened.

6) Verticality check of cabinet in two planes and nuts to be screwed.

7) The side covers to be installed and screws to be screwed.

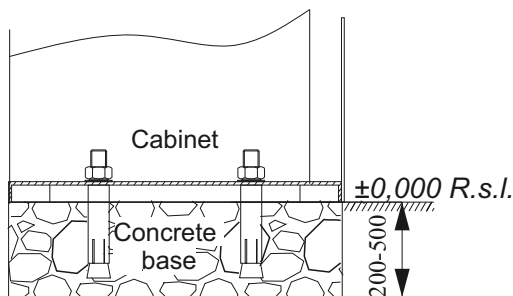
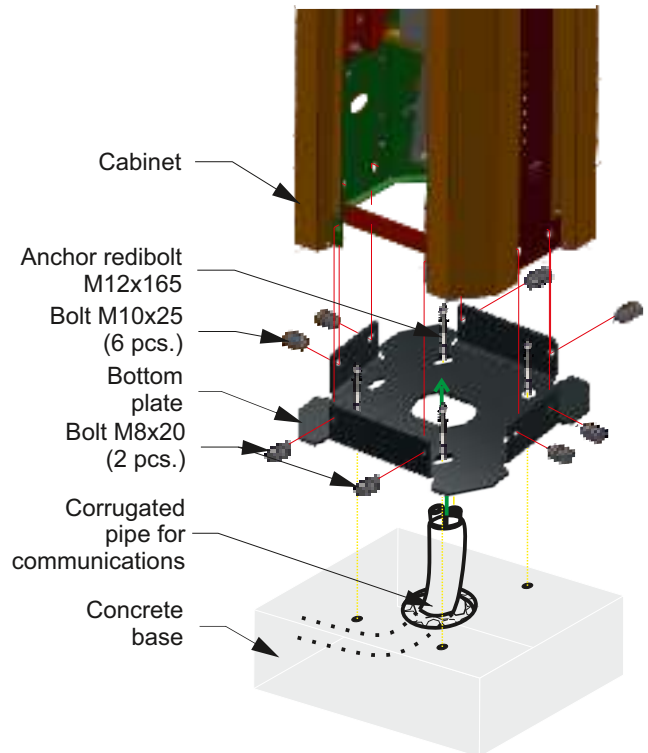

Verticality check of cabinet in two planes

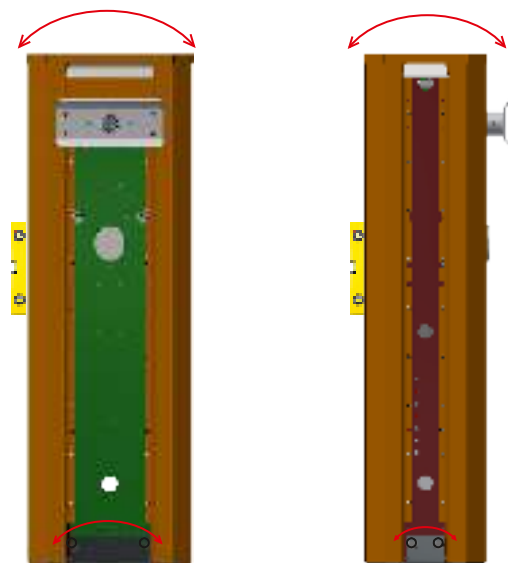

The fixed barrier cabinet must be strictly vertical in two planes.

BOOM BARRIER

Option 2* - Laying the bottom plate for foundation

- 1) Dig a pit for the bottom plate;
- 2) Install a corrugated pipe for communications for laying electrical cables;
- 3) Level the bottom plate horizontally with the help of the building level;
- 4) Concrete the base plate;
- 5) The Bottom plate to be installed and nuts to be screwed.
- 6) The Cabinet to be installed and bolts to be installed and nuts to be tightened.
- 7) Verticality check of cabinet in two planes and nuts to be screwed.
- 8) The side covers to be installed and screws to be screwed.



Concreting to be carried out in accordance with existing standards. The required electrical cables must be routed out of the concrete base.

*Option

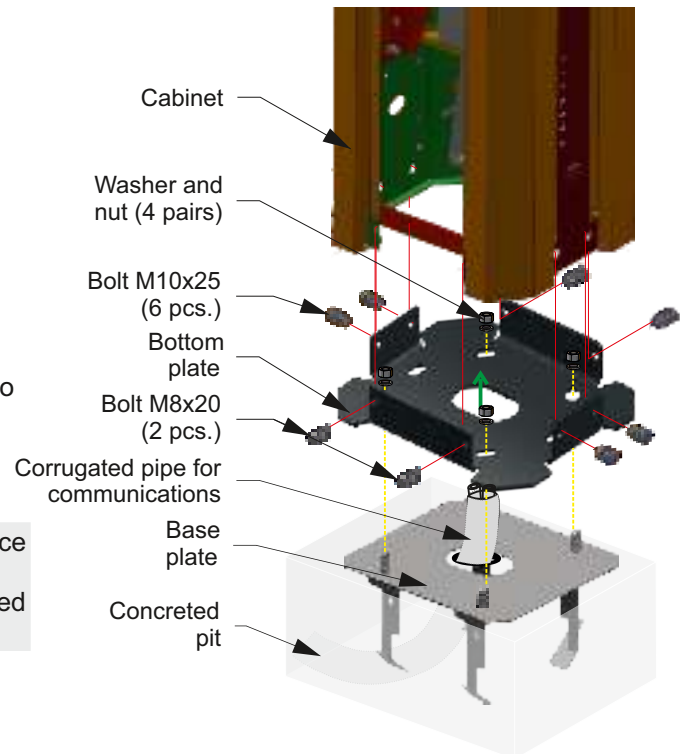

6.4 Barrier arm mounting

6.4.1 Barrier arm installation

- 1) Fix the barrier arm with the seal on both sides with the fixing plate to the arm holder and fix screws M10x75 (4 pcs);



Before installing the barrier arm, it is recommended to connect arm lighting (if arm lighting is provided in the order (see section 7).

- 2) Connect the electronic control unit (see section 7);
- 3) Perform the fast adjusting process from the controller (see section 6.4.2);
- 4) Give the "Open" command to raise the barrier arm from the control panel to check the verticality.

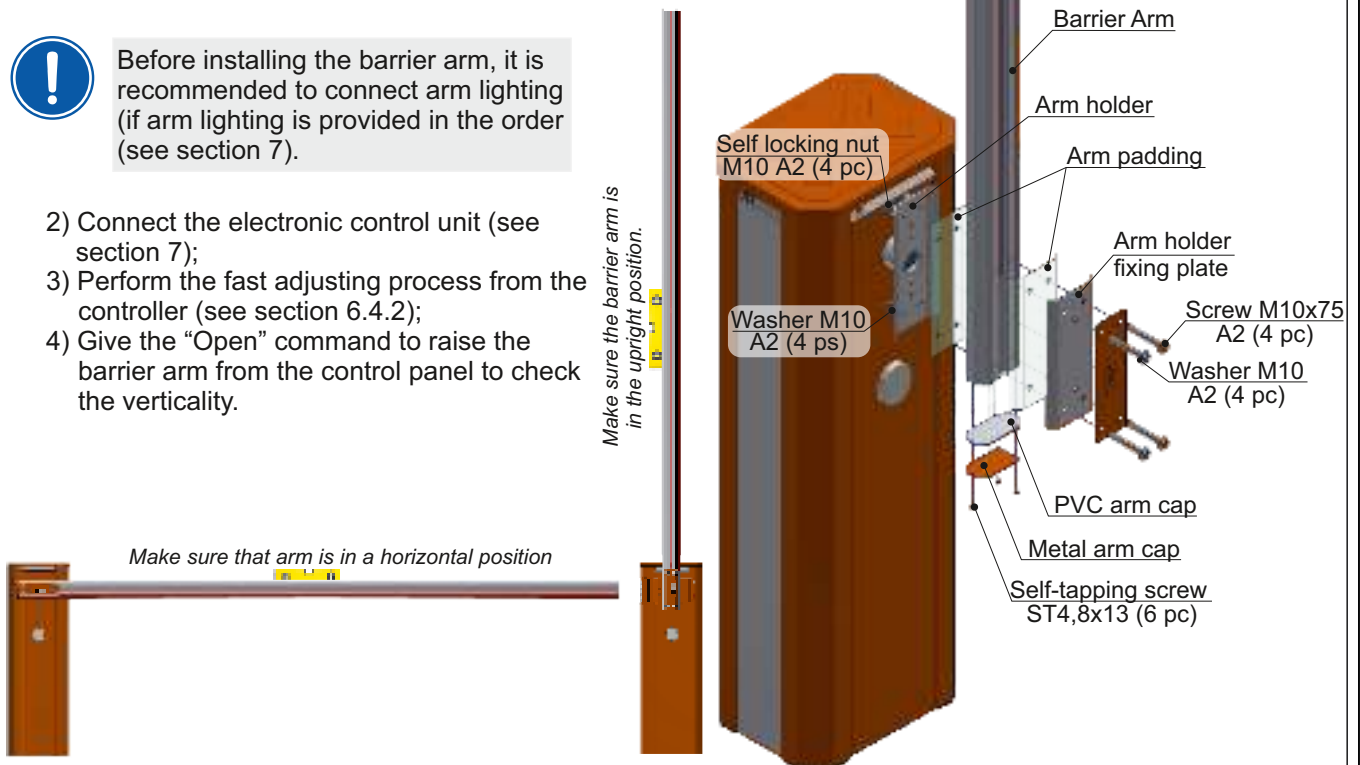

In the end positions of the barrier (open / closed), the barrier arm must be strictly vertical and horizontal.

ROAD BLOCKING SYSTEMS



Office and Production site:
14 Promyslova str., 02088, Kyiv, Ukraine,
E-mail: sales@tiso.global

Tel.: +380 (44) 291-21-11
Fax: +380 (44) 291-21-02
www.tiso.global

BOOM BARRIER

6.4.2 Fast adjusting process

For quick barrier adjustment, start the learning process from the controller according to the block diagram.

Brief description of the adjusting process:

1. Enter the Main Menu

- Press and hold the menu button for more than 2 seconds until "Pxx" appears on the display.

2. Barrier Running Learning (P00)

- Press the OPEN/+ or CLOSE/- buttons, select P00, and press Confirm.
- The barrier will perform a full open-close cycle.
- After completion, "OFF" will be displayed.

3. Remote Control Learning (P01)

- Select P01 and press Confirm.
- Program the remote control and check its operation.

4. Check the Barrier Running Direction (P02)

- If the running is correct, go to the next step.
- If incorrect, go to menu P02 and change the value to "000" or "001" to adjust the direction.

5. Barrier Position Adjustment (P03, P04)

Set the menu parameters of P03 and P04 (you can first open and close the gate with the remote control to see whether the lever is vertical or horizontal, if no problem, you can skip this step directly):

- Enter P03, press Confirm, then turn the motor handle to set the barrier to the vertical position. Press Confirm to save.
- Enter P04, press Confirm, then turn the motor handle to set the barrier to the horizontal position. Press Confirm to save.

6. Speed Adjustment (P05, P06)

Use the remote control to open/close the barrier and check its speed. If adjustment is needed:

- P05: Opening speed
 - P06: Closing speed
- Press Confirm, change the value, then press Confirm again. Higher values increase speed.

7. Deceleration Adjustment (P07, P08)

- P07 – Deceleration angle for opening.
 - P08 – Deceleration angle for closing.
- Press Confirm, change the value, then press Confirm again. Higher values cause earlier and slower deceleration.

8. Test and Save Adjustment

- Use the remote control for testing.
- If everything works correctly, press and hold the menu button for 2 seconds to exit.

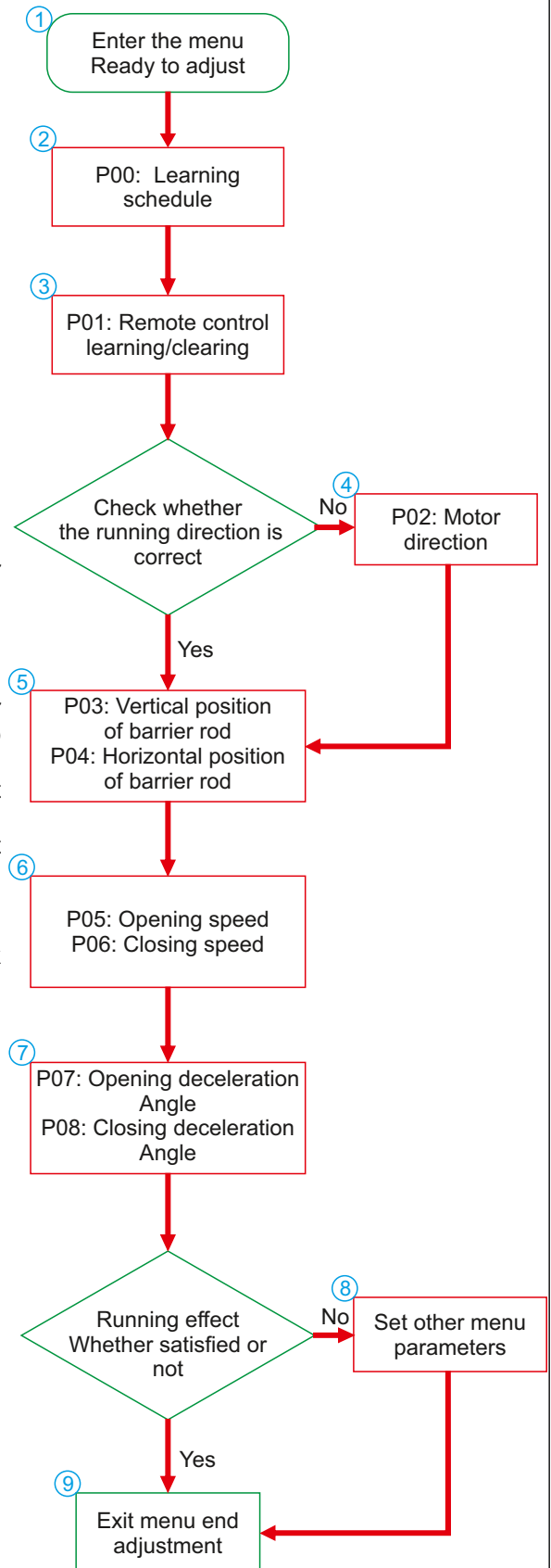

BOOM BARRIER

6.4.3 Arm balancing



Always turn off the electricity when setting up the boom barrier!

- Check the condition for correct arm balancing (spring operation):
 - in the vertical arm position, the spring is in a free state;
 - in the horizontal arm position, the spring is in a tensioned state;
 - in the 45° position, arm neither lower nor raise;
- If the balance of the system is not achieved and there is a difference in force when arm moving from the end positions, the arm must be balanced. For this should be done:

- 1) cabinet door to be opened with key from the kit;
- 2) barrier cabinet cover to be removed;
- 3) unlock the drive, unscrew the linkage arm fixing screw;
- 4) set the boom at 45° using manual control and check the system balance;
- 5) balance the arm by tightening or loosening the balancing spring nut;
- 6) lock the drive by tightening the linkage arm fixing screw with a torque of 50 N m.

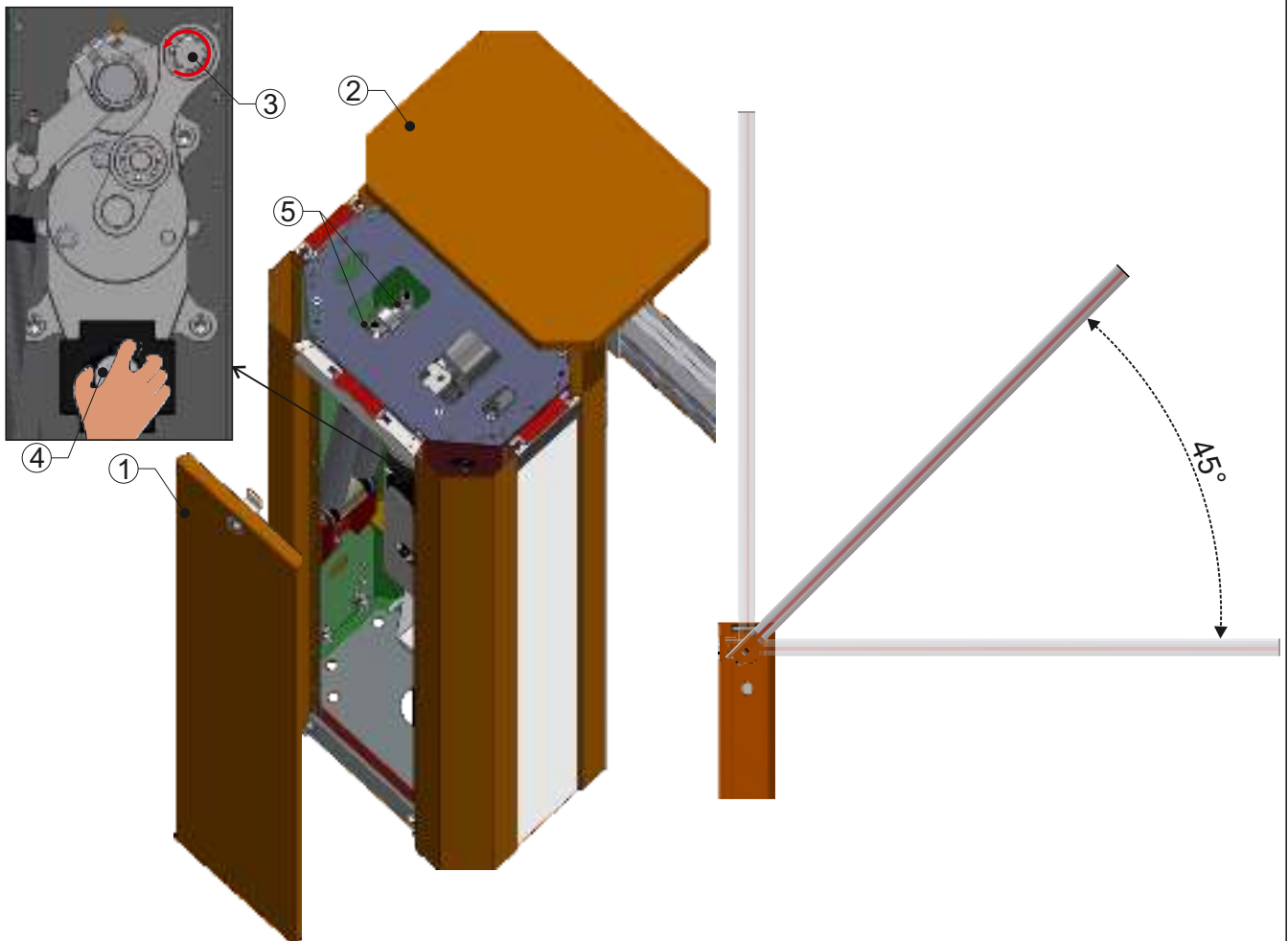

The arm is correctly balanced if it moves smoothly, without jerking and remains fixed at the end of stroke; the force required to raise the boom from a horizontal position should be equal to the force required to lower the boom from a vertical position. The horizontal and vertical line alignment can be adjusted by moving the stops.

ROAD BLOCKING SYSTEMS



Office and Production site:
14 Promyslova str., 02088, Kyiv, Ukraine,
E-mail: sales@tiso.global

Tel.: +380 (44) 291-21-11
Fax: +380 (44) 291-21-02
www.tiso.global

BOOM BARRIER

6.4.4 Arm position adjustment



At closing, the optimal position of the arm is parallel to the roadway, at opening - $\sim 90^\circ$.
The barrier arm is correctly adjusted if arm takes an optimal position in relation to roadway and movement of barrier mechanism lever is limited by stops.
The boom is correctly adjusted when it is sufficiently stable in the 0° and 90° positions.

When starting the quick adjustment of the barrier from the controller, the horizontality and verticality of the boom are not achieved, then it is necessary to manually adjust the horizontality.

Horizontal Angle Adjustment of Barrier Boom (Mechanical Adjustment)

Adjust the horizontal position of the barrier boom:

If the barrier arm is not in a horizontal position and is tilted, the following actions must be taken:

- 1) Loosen the 2 screws of the sprindle connecting arm;
- 2) Turn the barrier boom to the horizontal position;
- 3) Tighten the screws with a torque of 50 N m.

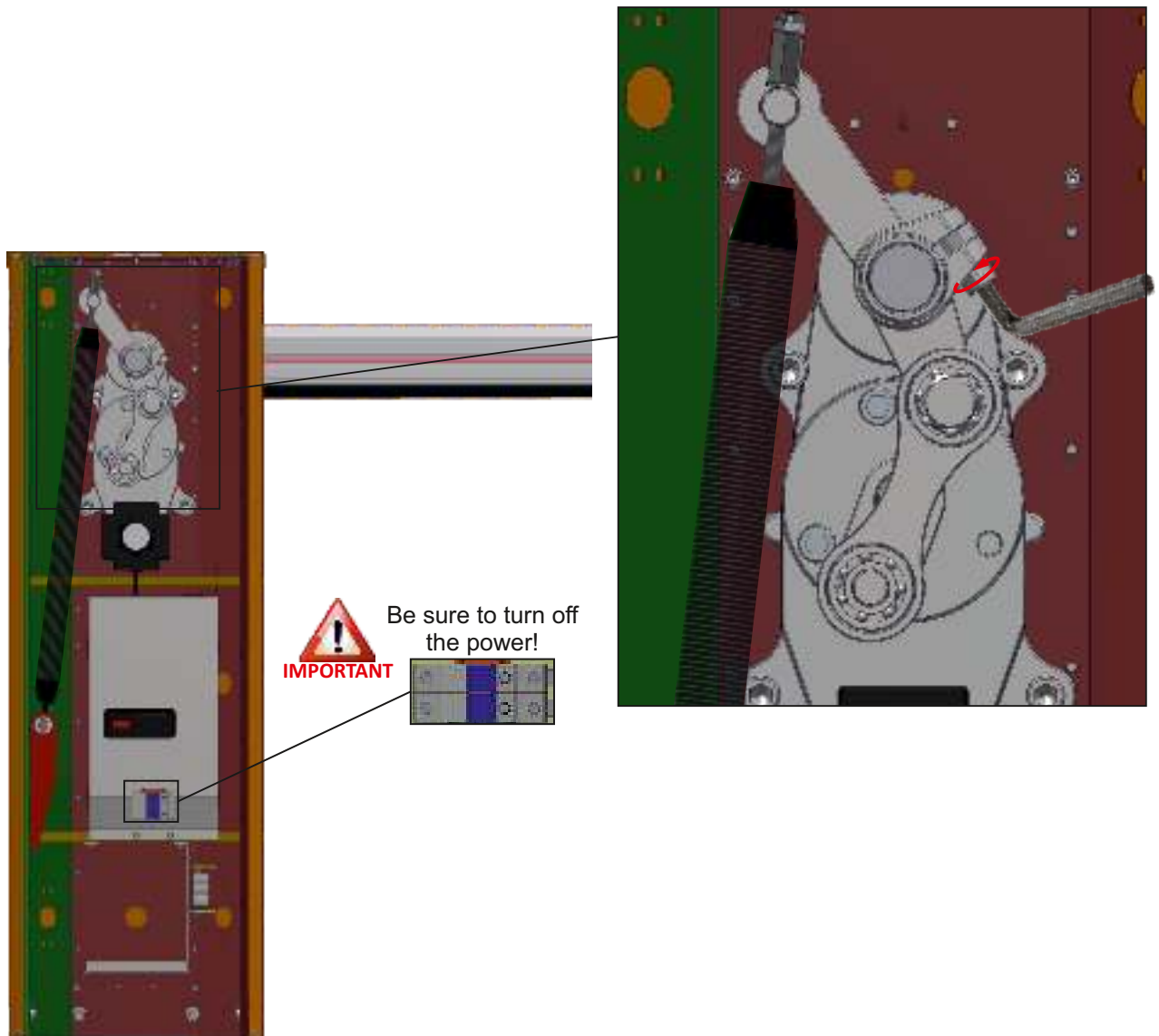

BOOM BARRIER

6.5. Manual control

In cases where there is no electricity, boom barrier models have a manual control mode.



When performing manual opening / closing operations, the boom barrier must be disconnected from the mains so that an accidental command does not set the boom barrier in motion.

For manual control of the boom barrier it is necessary to:

- turn off 230V power supply;
- open the boom barrier cabinet door and use the manual control handle by means of which the boom can be raised and lowered.

In order to return to automatic control mode, the power must be connected.



- Use caution when using the boom barrier handle as barrier arm can move quickly due to loosen or broken springs. Move the barrier arm at a moderate speed during manual control!
- Do not use manual control without barrier arm installed!

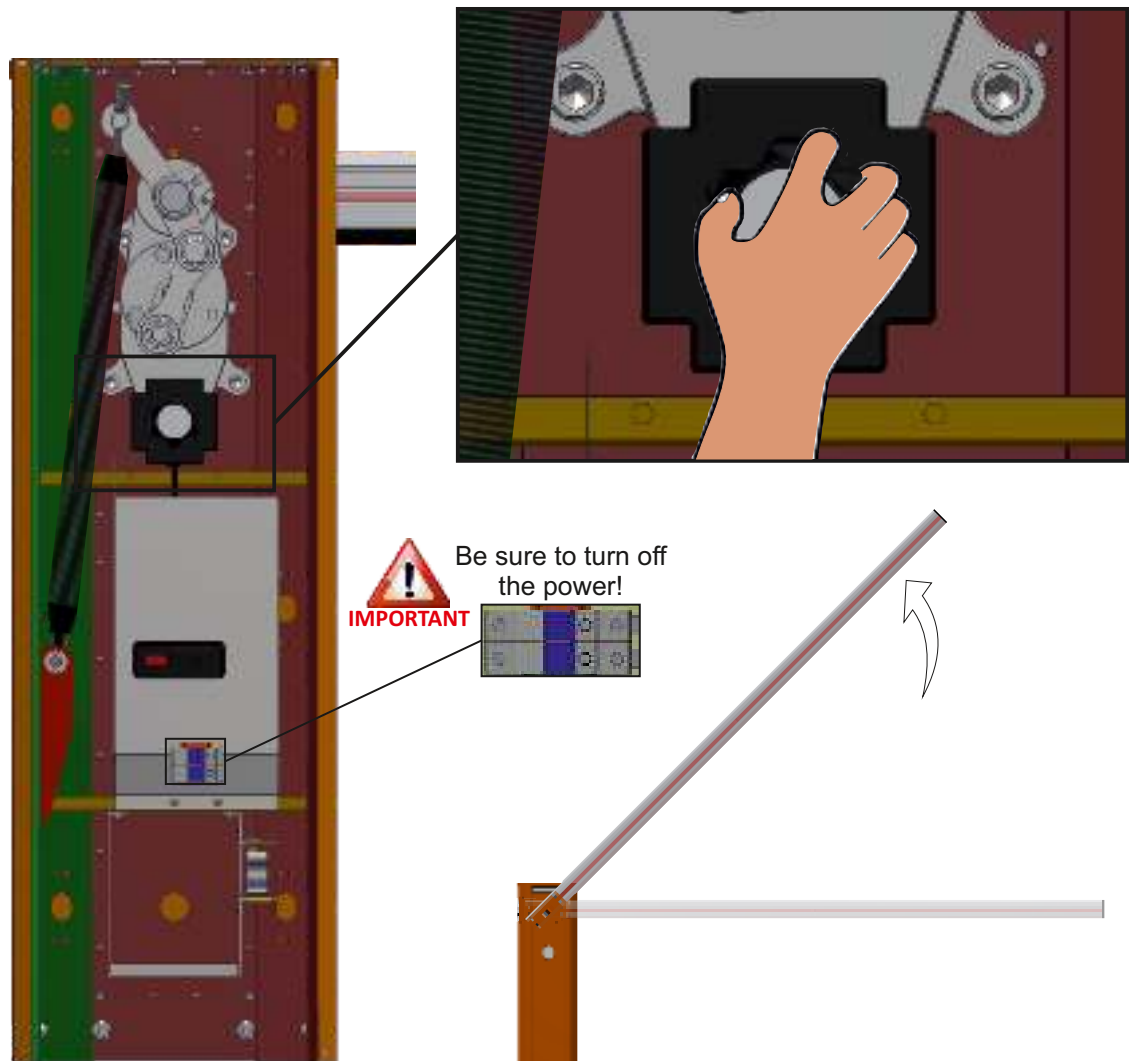

BOOM BARRIER

6.6 Versions of Boom barrier

Table 4

Right version of boom barrier		
Arm	in a horizontal position	in an upright position
Sector	in the top position	in the lower position
Spring	uncompressed	compressed

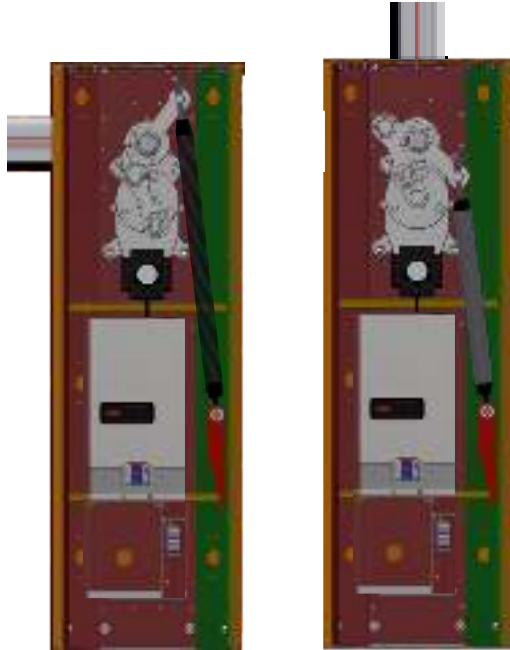

Right version of boom barrier

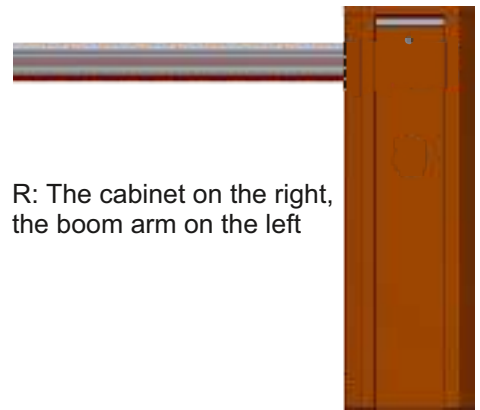

R: The cabinet on the right, the boom arm on the left

Table 5

Left version of boom barrier		
Arm	in a horizontal position	in an upright position
Sector	in the top position	in the lower position
Spring	uncompressed	compressed

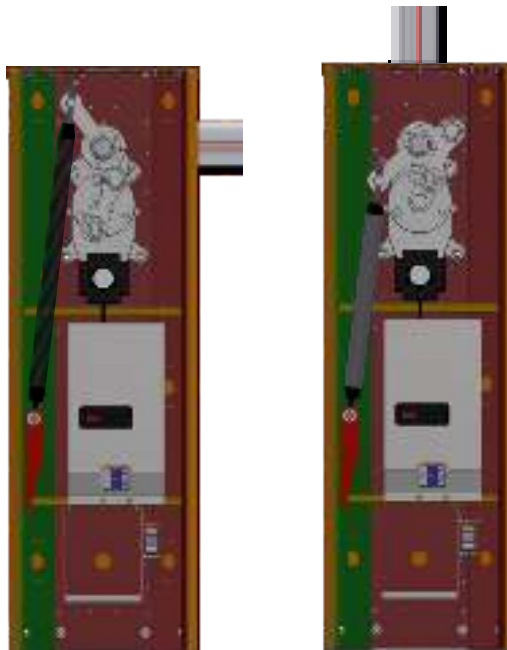

Left version of boom barrier

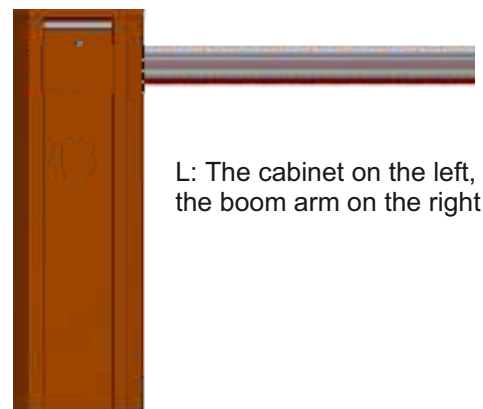

L: The cabinet on the left, the boom arm on the right

ROAD BLOCKING SYSTEMS



Office and Production site:
14 Promyslova str., 02088, Kyiv, Ukraine,
E-mail: sales@tiso.global

Tel.: +380 (44) 291-21-11
Fax: +380 (44) 291-21-02
www.tiso.global

BOOM BARRIER

6.7 Changing the direction of the barrier arm



Always disconnect the power supply when changing the direction of the barrier arm!

The direction of the barrier arm must be changed without the arm and springs installed!

Screws must be tightened to 50 N m!

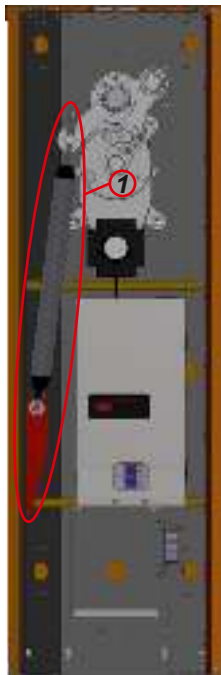

To change the direction of the barrier arm, follow these steps:

1. Remove the springs assembled with the bracket;
 2. Pull out the cotter pin connecting the rocker arm and the linkage arm;
 3. Unscrew the arm fixing screw;
 4. Loosen the screws on the spindle connecting arm;
 5. Rotate the linkage arm clockwise for a mirrored configuration;
 6. Remove the rocker arm;
 7. Unscrew the upper and lower restrictor for the barrier arm movement;
 8. Use the manual control handle to move the crank arm to the left.
- Reassemble in reverse order.

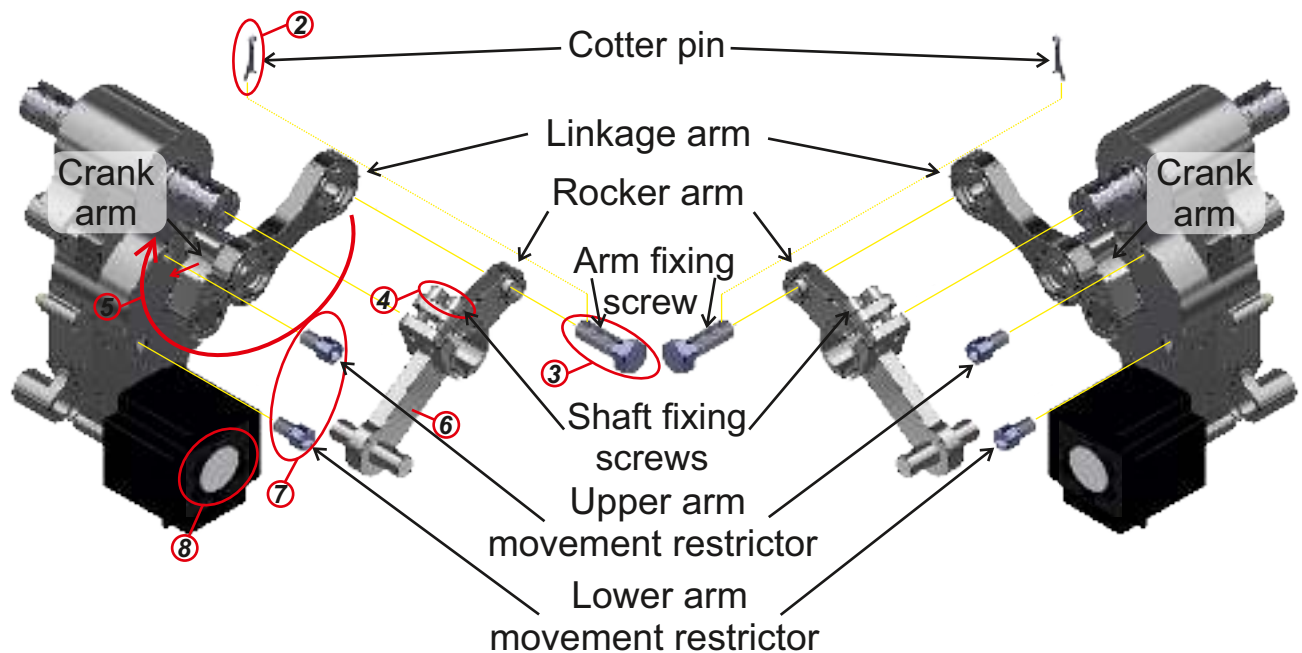
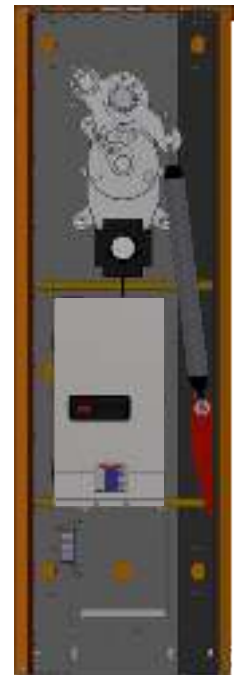

BOOM BARRIER

7. Connection of boom barrier utilities



- Before connecting boom barrier, check that cabinet and arm are installed correctly and securely.
- Only specialists with appropriate qualifications are allowed to work on connecting of boom barrier utilities.
- Connect utilities of boom barrier with power supply disconnected!
- To protect electrical cables from mechanical damage and harmful environmental influences, it is recommended to lay the cables in a corrugated polyamide pipe with waterproof sealed connectors.

7.1 Main connection of boom barrier

The control unit is located inside the barrier cabinet.

- a) ~230 V power supply cable to be connected:
- Phase (L) to be connected to the circuit breaker;
 - Neutral (N) to be connected to the circuit breaker;
 - Earth (PE) to be connected to earthing terminal (PE);

Electronic control unit

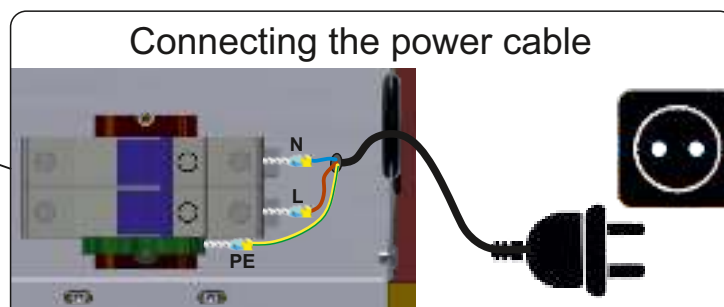
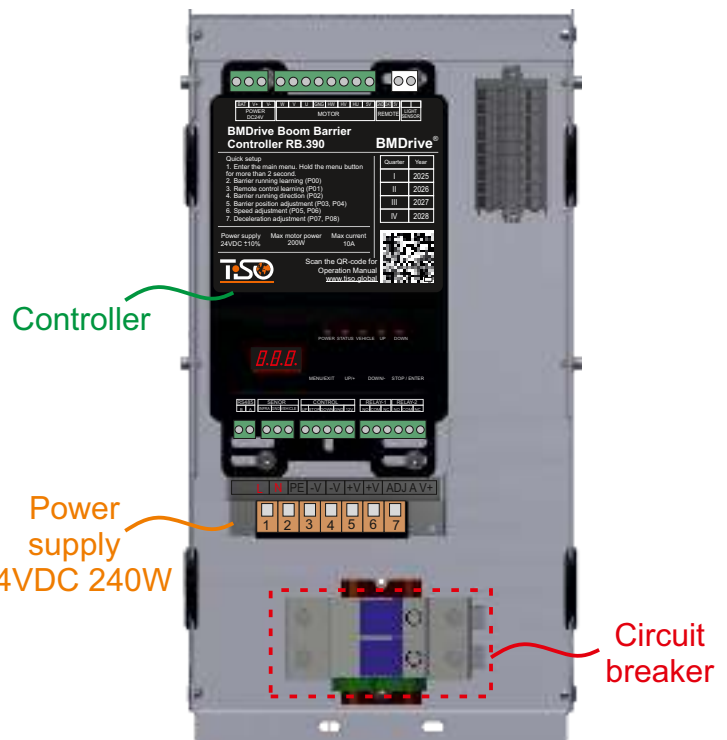

- Carefully study the power supply connection diagrams of "Operation Manual. Part II. Wiring and operation of boom barriers"
- The connection must correspond to the wiring diagram shown in the diagram in Appendixes 1-2 of the Operation Manual. Part II. Wiring and operation of boom barriers"

ROAD BLOCKING SYSTEMS



Office and Production site:
14 Promyslova str., 02088, Kyiv, Ukraine,
E-mail: sales@tiso.global

Tel.: +380 (44) 291-21-11
Fax: +380 (44) 291-21-02
www.tiso.global

BOOM BARRIER

7.2 Controller

The controller is designed to control the barrier, process signals from control devices and send information about the barrier status to external devices.



BOOM BARRIER

7.3 Connection of barrier arm lighting

1. Lay the LED strip into the groove of the arm and pull the cable **a** through the existing service hole **5** in the arm.

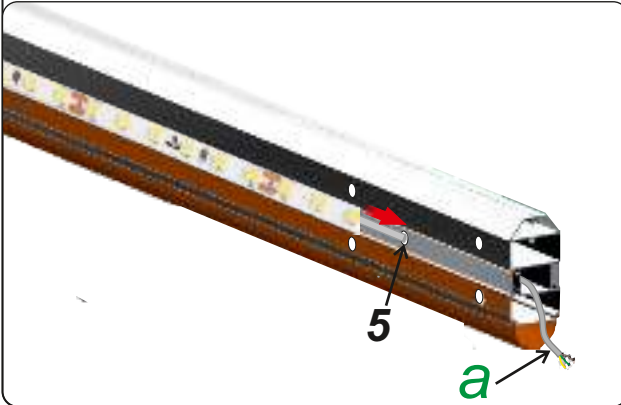

2. Lay the LED strip on the other side into the groove of the arm and pull cable **b** through the existing service hole **4** in the arm.

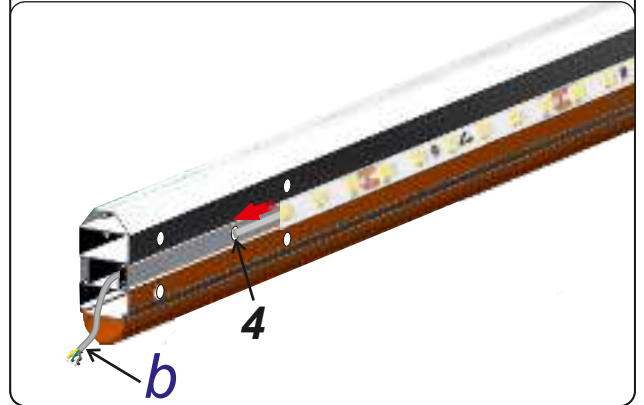

3. Pull power cable **c** from the Electronic Control Unit of the boom barrier through the housing and the existing service holes **1** in the housing, hole **2** in the arm holder, hole **3** in the arm padding and holes **4** in the arm.

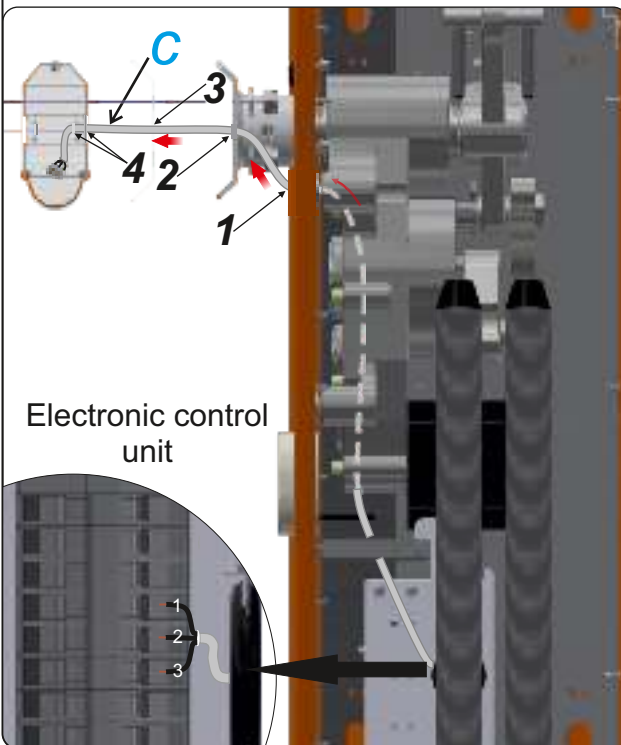

Electronic control unit

4. Connect the terminal block of cable **c** to cables **a** and **b**. Check their routing inside the arm.

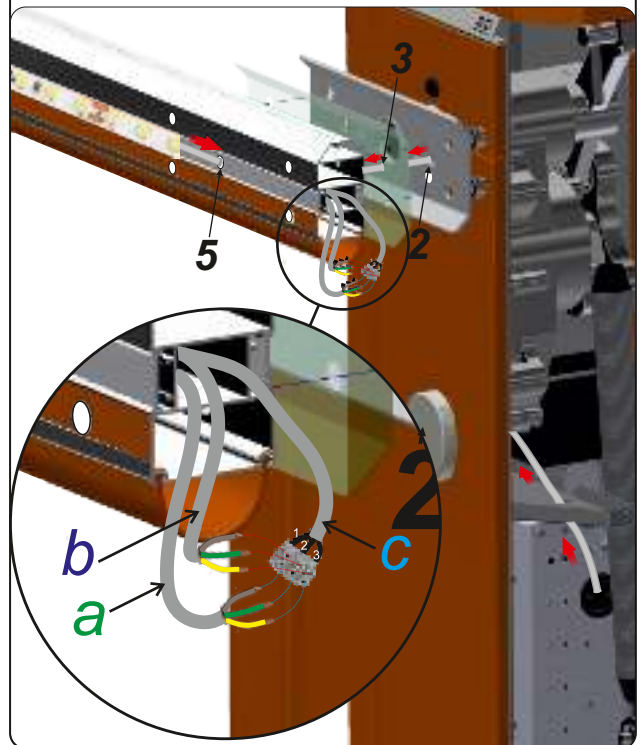

ROAD BLOCKING SYSTEMS



Office and Production site:
14 Promyslova str., 02088, Kyiv, Ukraine,
E-mail: sales@tiso.global

Tel.: +380 (44) 291-21-11
Fax: +380 (44) 291-21-02
www.tiso.global

BOOM BARRIER

7.4 Connection of barrier arm bumper lighting

1. At a distance of 75 mm from the beginning of the arm, drill a hole in both walls of the arm for routing the bumper lighting cable. **Be sure to remove sharp edges from the holes!**

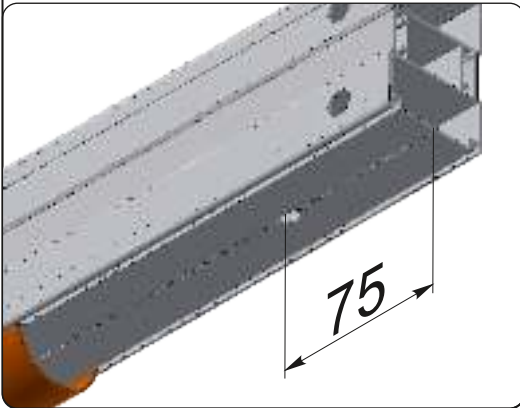

2. Lay the LED strip, secure it with clips, and pull cable **a** through the existing service hole **5** in the arm.

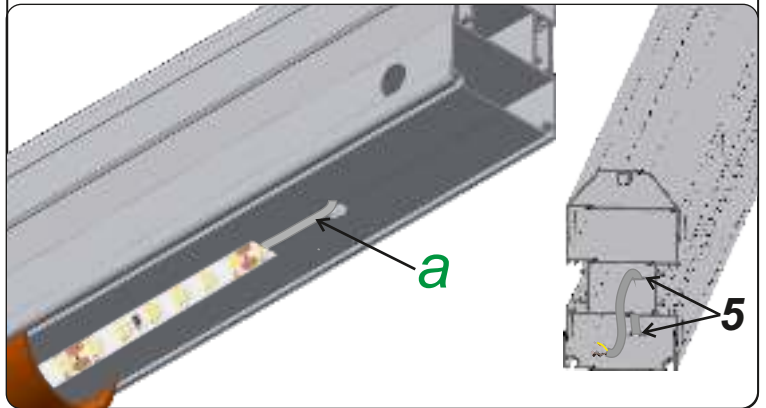

3. Pull power cable **c** from the Electronic Control Unit of the boom barrier through the housing and the existing service holes **1** in the housing, hole **2** in the arm holder, hole **3** in the arm padding and holes **4** in the arm.

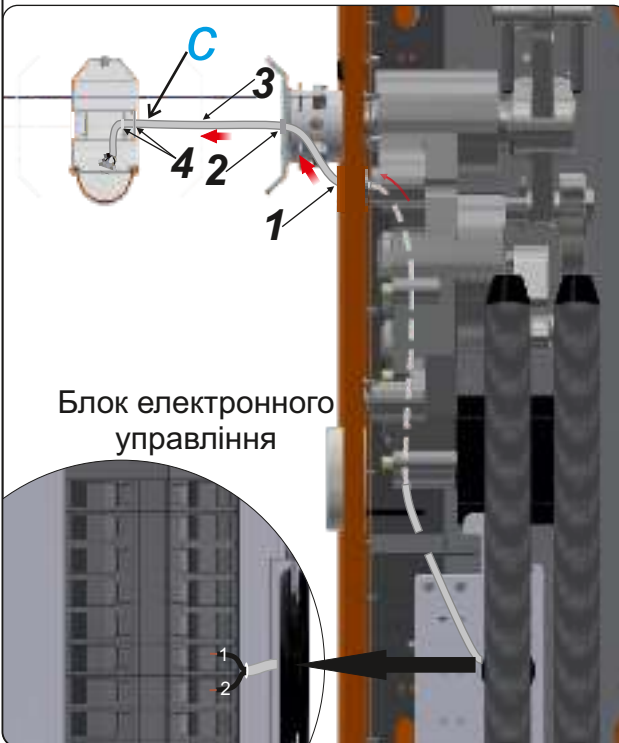

4. Connect the terminal block of cable **c** to cables **a**. Check their routing inside the arm.

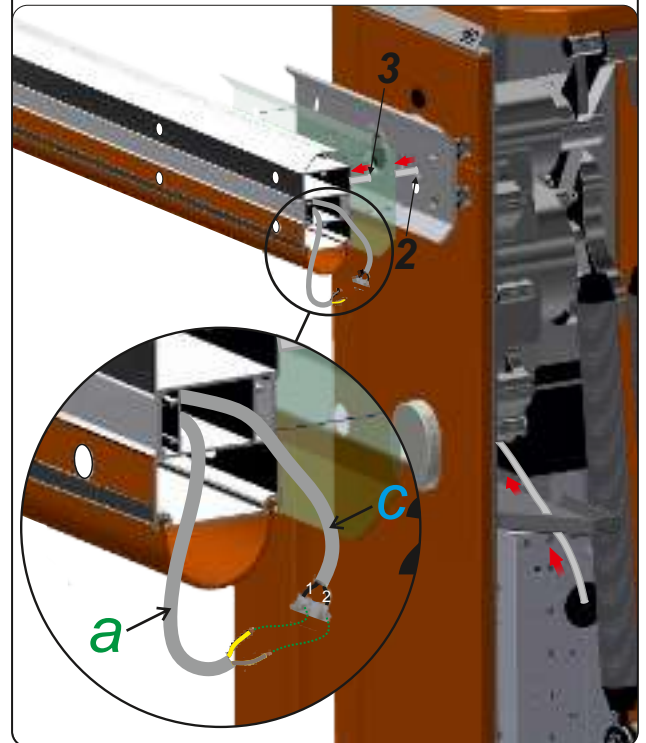

ROAD BLOCKING SYSTEMS



Office and Production site:
14 Promyslova str., 02088, Kyiv, Ukraine,
E-mail: sales@tiso.global

Tel.: +380 (44) 291-21-11
Fax: +380 (44) 291-21-02
www.tiso.global

BOOM BARRIER

7.4. Installation and connection of IR barriers (safety sensors)

Safety sensors can be mounted on posts (included in the optional scope of delivery).

Do not install posts too close to the edge of roadway, recommended distance is at least 10 cm, in order to avoid damage when driving through boom barrier. To form the control zone outside the arm of boom barrier, two posts are installed on opposite sides of roadway: a transmitter is mounted on one post, a sensor receiver is on the other.

Place the receiver and transmitter of the safety sensors turn on each other.

Make the connection in accordance with diagram in Appendix 2 (OM, Part II).

Entry IR barriers are connected to the controller in the electronic control unit.

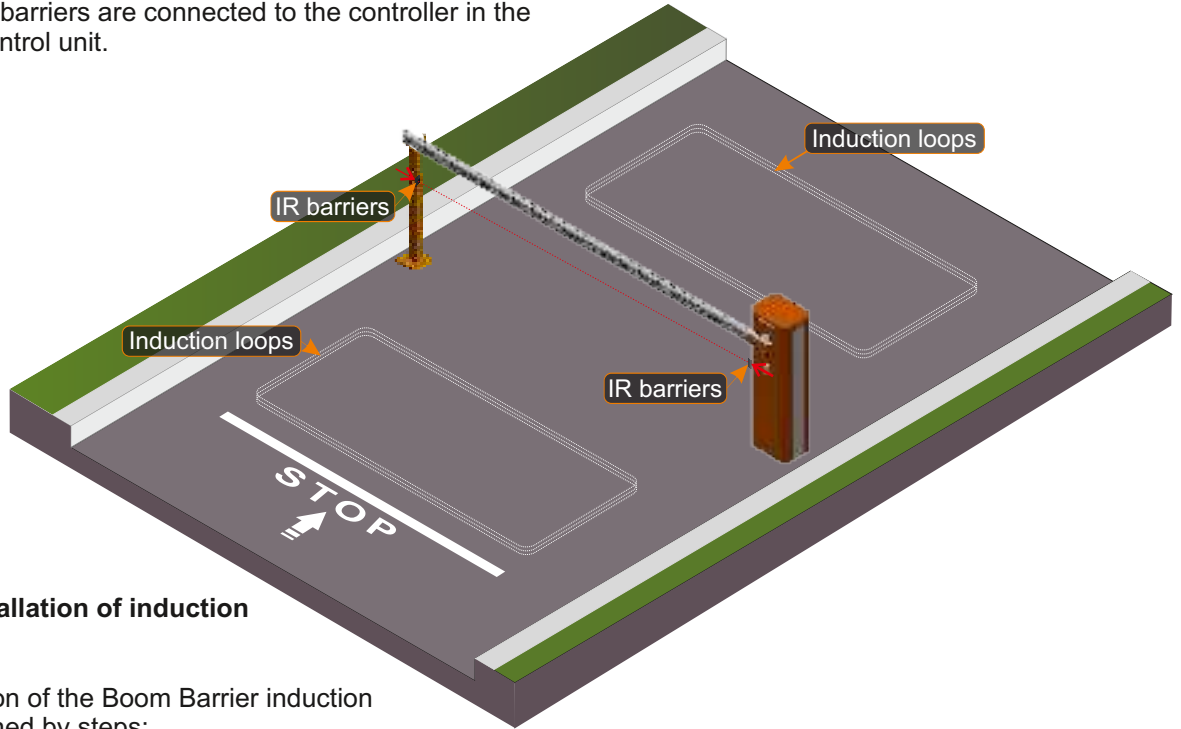

7.5. Installation of induction loops

Installation of the Boom Barrier induction loops is defined by steps:

- Definition of loop geometry;
- Preparation of slot;
- Laying of wire;
- Asphalt or synthetic resin grouting;
- Check of induction loop detector function;

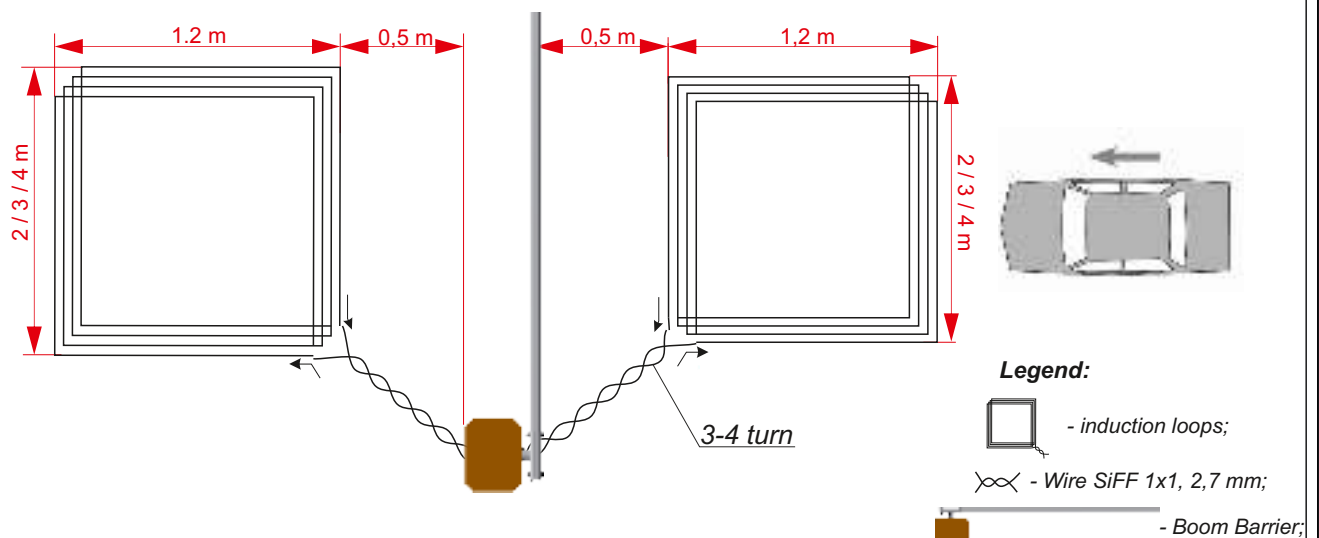

BOOM BARRIER

Definition of loop geometry

- Loops to be located within at least 50 cm from metal objects;
- Loop installation depth to be 30mm-50mm from road surface;
- Loop to be made by means of one cable without any joints or shunts inside pit;
- Two cable ends going out of perimeter outline to be twisted or bound with each other;
- Loop shape to be rectangular;

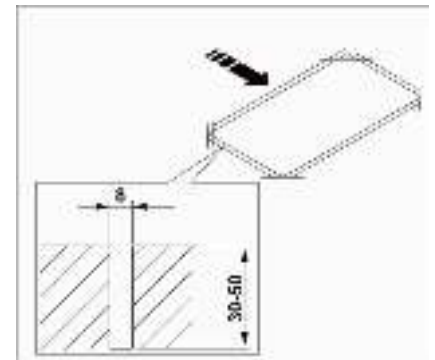

Preparation of slot

- Deep slot to be prepared (width 5-10 mm and depth 30-40 mm);
- Loop slot shape to be rectangular
- Corners to be cut at angle 45° to prevent failure of cable due to vibration of transit vehicles or possible subsidence of road surface;

Laying of wire

- Loop wire to be laid in slot as deep as possible.
The number of loop turns and size to be selected from "Table 19 - Recommended sizes of loops and height of vehicle deduction over induction loop" of the document "Operation Manual. Part II. Wiring of the RB serie Boom Barriers".
- Heat-resistant and extra-flexible wire SiFF 1x1 with outside diameter 2,7mm is recommended for loop laying;
- Led to loop wire to be twisted at least 20 times per meter and to be put in slot or plastic pipe;

Asphalt or synthetic resin grouting

Asphalt or synthetic resin can be used as potting material. Temperature should not exceed loop isolating value during pouring (The permissible temperature limit for heat-resistant and extra-flexible wire SiFF is -60°C to +180°C).

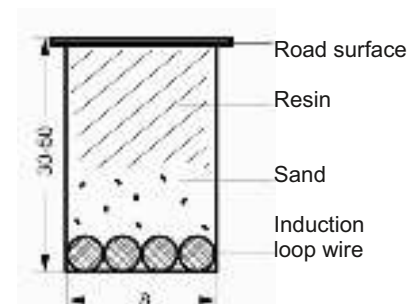

BOOM BARRIER

8.

Precommissioning



ATTENTION!

Before using the product, make sure that all safety components are in order and correctly installed. Please note that the product may have been damaged during transportation. Do not disconnect safety components or try to modify them. In case of any malfunction or defect, notify the service manager.

8.1 Preparation for precommissioning:

- Compliance and reliability of boom barrier electrical cable connections and control unit to be checked;
- The roadbed around boom barrier to be restored;
- The equipment power network to be checked;
- Reliability of connection with earth loop to be checked.



Precommissioning, equipment adjustment, troubleshooting to be performed only by the properly qualified professionals! It is necessary to comply with safety regulations during precommissioning and equipment adjustment!

8.2 Precommissioning:

- Gear motor and control unit to be energized;
- Boom barrier trial operation to be conducted;

During the trial cycle, check the operating parameters of gear motor, unit controls, remote controls and general operation of boom barrier.

If necessary, adjust the required parameters of the equipment.









After a test run and check, the cable glands to be carefully clamped to prevent from water entering! In case of malfunction that cannot be eliminated using the information in this Manual, you must contact the service department.

8.3 Controlling the operation of boom barrier

The boom barrier can be controlled using manual control, remote control (button, switch) or ACS controller. These devices can be connected to boom barrier separately, all together (in parallel) or in any combination with each other.

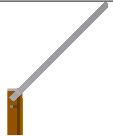
Table 6 - Boom barrier operation using wired control panel

Command	Operator actions	Command on control panel	Boom barrier condition	Passage condition
-	-	-		Forbidden / boom barrier closed 
Open the passage	Press the button "UP"		The boom barrier will rise to the upper position and stop.	Permitted / boom barrier open 
Stop the movement of boom barrier	Press the button "STOP"		Stop and will be in static position until new commands are given	Forbidden / boom barrier partially closed 
Close the passage	Press the button "DOWN"		The boom barrier will rise to the lowest position and stop.	Forbidden / boom barrier closed 

ROAD BLOCKING SYSTEMS



Office and Production site:
14 Promyslova str., 02088, Kyiv, Ukraine,
E-mail: sales@tiso.global

Tel.: +380 (44) 291-21-11
Fax: +380 (44) 291-21-02
www.tiso.global

BOOM BARRIER

9.

Routine maintenance

9.1. Spring replacing

1. Open the cabinet door with the key.
2. Remove the cabinet cover by unscrewing 8 M4 nuts.
3. Remove the side cover by unscrewing the 4 M4 screws.
4. Raise the barrier to the vertical position using the manual control.
5. Unscrew two M8 self-locking nuts and two extended nuts that secure the springs to the mechanism.
6. Unscrew three M8x20 screws on the lower part of the cabinet and remove the assembled springs with the bracket from the barrier cabinet.
7. Remove the cotter pin, remove the locking pin and replace the springs.
8. Reassemble in reverse order.
9. Balance the barrier arm.



Be sure to turn off the power!

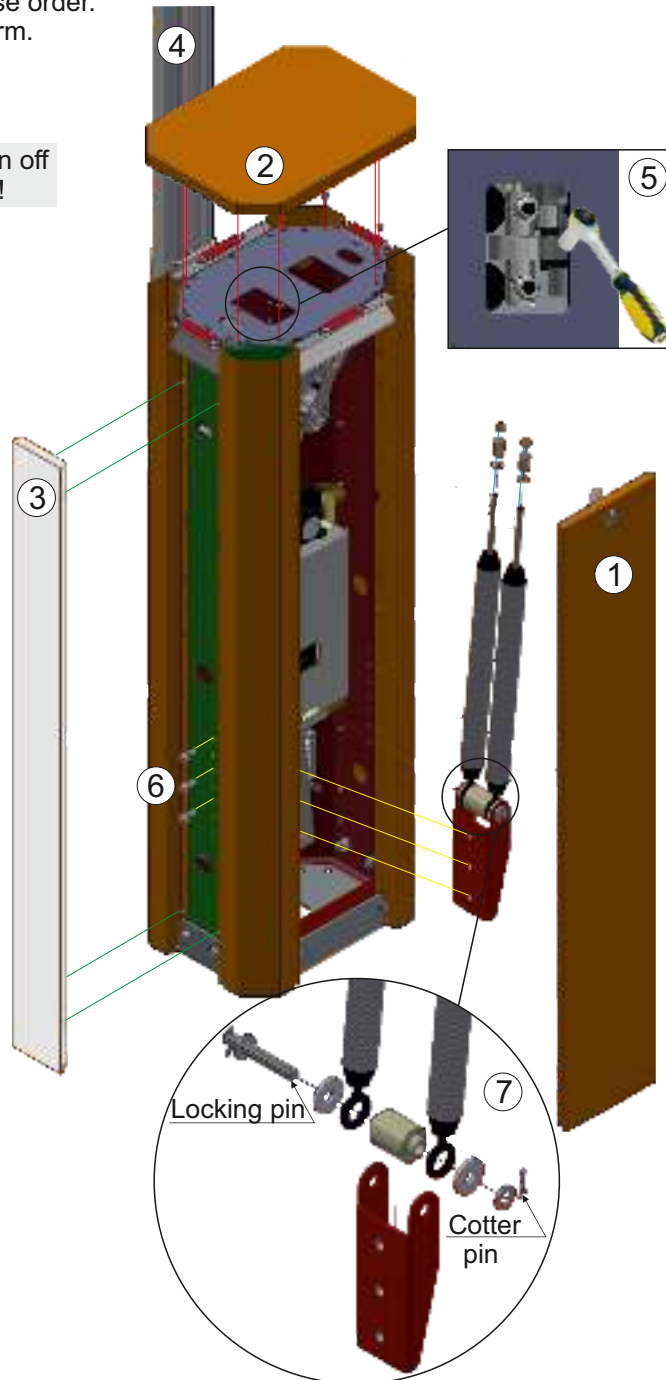

ROAD BLOCKING SYSTEMS



Office and Production site:
14 Promyslova str., 02088, Kyiv, Ukraine,
E-mail: sales@tiso.global

Tel.: +380 (44) 291-21-11
Fax: +380 (44) 291-21-02
www.tiso.global

BOOM BARRIER

9.2. Possible malfunctions

If a malfunction is detected, it is necessary to establish its cause and if possible to repair it.

Table 7 - Boom Barrier troubleshooting

Malfunction 1	Probable cause of malfunction 2	Action 3
The boom barrier does not work (no indication of control unit)	Network voltage is absent or fuse is blown	Network voltage to be checked. Fuse to be checked and replaced, if appropriate (fuse parameters to be complied with label)
The boom barrier does not work (there is an indication of control unit)	Error in the electrical connections. Obstacles for barrier arm movement.	Check the connections. Remove the obstacle
The barrier arm does not stop in the end points	End points not configured or lost	Adjust the position of circuit breakers of end points of boom barrier
The barrier arm is raised/lowered unevenly, by jerks or stops	Boom is not balanced	Boom barrier balancing springs to be adjusted
The barrier arm is not fully raised/lowered	Incorrect adjustment of end switches	Adjust the end switches
The barrier does not react to an obstacle on optical axis of safety sensors when closed	Safety sensors are faulty	Check safety sensors, replace them if necessary

* In case of a malfunction which cannot be solved using the information from this Manual, contact the service department.

BOOM BARRIER

10.

Boom barrier operation regulations

10.1 Rules of operations

To ensure the Boom Barrier continuous and reliable operation it is necessary:

- to use the product according to its intended purpose;
- all rules specified in this Manual shall be strictly observed during operation;
- to provide maintenance and repair of equipment in due time;
- to prevent the Boom Barrier operation and maintenance to be performed by unauthorized persons;



It is forbidden:

- to touch the Boom Barrier arm during its operation;
- to prevent Boom Barrier raising/sinking;
- to initiate movement of vehicles prior to complete Boom Barrier sinking

10.2 Equipment maintenance:

The Boom Barrier maintenance includes preventive measures to be taken according to the established frequency to maintain Boom Barrier in operational condition, decrease component wearing and prevent faults and malfunctions.



The equipment examination and maintenance to be performed according to the Schedule and only by the properly qualified professionals.

Table 8 - Boom Barrier maintenance schedule

M type	Frequency	Scope of control/work
1	2	3
Daily inspection	each shift	Daily maintenance is performed before commencement of work and includes: <ul style="list-style-type: none"> - visual inspection of Boom Barrier; - if required, prompt mechanical troubleshooting, elimination of corrosion and surface pollution; - availability of all units and sensors in their proper locations and their fastening are reliable; - performance of all sensors and cable integrity; - Boom Barrier normal operation without jerks and abnormal noises, jamming of movable constructional elements; - motor heating (over 70°C).
M-1	monthly	M-1 is performed monthly and includes the following measures: <ul style="list-style-type: none"> - measures in the scope of daily inspection; - elimination of dust and dirt from the Boom Barrier housing and components; - cleaning of actuators, sensors and actuators; - verification of sensors fixation reliability and their performance; - verification of good condition and fastening security of cable connections to actuators, sensors; - check of availability and integrity of protective fences and devices.
M-2	semiannually	M-2 maintenance is performed semiannually including the following types of work: <ul style="list-style-type: none"> - measures in the scope of M-1; - verification of fastening security of units and devices; - check of lever tightening; - check of spring, circuit and relative anchors; - check of barrier arm balance; - make sure that at the end of stroke the lever is horizontal and / or upright position; - check of operation of control unit and safety devices;

ROAD BLOCKING SYSTEMS



BOOM BARRIER

Continued Table 8

1	2	3
M-3	annually	M-3 maintenance is performed annually including the following types of work: - measures in the scope of M-2; - check of status of bearings, sealing cups and lubrication; - blowing and cleaning of terminal boxes; - tensioning of screw joints of terminal boxes; - check of reliability and quality of cable connections and earthing; - check of insulation resistance; - repair of paint coatings.
Major repair	after 3 000 000 cycles	- according to the manufacturer's documentation using the manufacturer's spare parts

Major repair is recommended to be performed by the manufacturer or the dedicated repair service according to the manufacturer's documentation with the use of the manufacturer's spare parts as well as restored or manufactured by special repair facilities according to the manufacturer's documentation.



The time of maintenance and major repair can be increased or decreased depending on actual parameters of the road blocker operation and fixed by the company operating this equipment.
All types of maintenance should be recorded in maintenance and repair work sheet.

10.3. Safety regulations:

10.3.1 The appropriate safety measures shall be observed during operation and maintenance of boom barrier.

10.3.2 The boom barrier must be repaired by the certified specialists having the relevant electrical safety qualification permit to work with electrical facilities, safety briefed at workplace and scrutinized the product instruction manuals.

10.3.3 It shall be the responsibility of boom barrier owner to ensure safety measures.

10.3.4 Hazardous characteristics during the boom barrier operation are:

- mechanical impact of raising/sinking dynamic part;
- electric shock by 230 V.

10.3.5 Service and repair shall be performed only when equipment is deenergized, a forbidding safety sign according to ISO 7010: 2011 with placard "Do not switch ON - men working!" is put on initiator.

After completion of works safety signs to be removed and equipment to be activated only upon authorization of the work superintendent.

Boom barrier from the mains is turned off with a switch (recommended bipolar circuit breaker or RCD (Diff Auto) when installing the boom barrier in the open air), which on the boom barrier connection line must be installed.

10.3.6 Boom barrier electrical equipment should be earthed. Resistance between earthing bus and each accessible metal non-current-carrying part of Boom barrier electrical equipment housing should not exceed 4 Ohm.

10.3.7 General safety requirements accepted in the particular company should be in effect during installation and operation of the Boom barrier.



The safety instructions specified in the instruction manuals for purchased products and control system to be additionally governed by during Boom barrier operation.

ROAD BLOCKING SYSTEMS



BOOM BARRIER



IT IS STRICTLY FORBIDDEN:

- to perform repair and maintenance work in electrical machines and parts of boom barrier under voltage;
- to perform repair and maintenance work with the equipment in operation;
- to allow the persons being unfamiliar with operation and safety rules to service a boom barrier;
- to use unearthed boom barrier;
- to touch movable parts of boom barrier during operation;
- to operate boom barrier when protective devices and switches are removed;
- to prevent boom barrier raising and sinking;
- to use metalwork of boom barrier for connection of neutral wire of electric welder;
- to perform welding works near the road blocker without noncombustible material protection to avoid its burning;
- allow children play with control panels. Keep control panels out of the children's reach.

11.

Notes:

QR-code to be used to download the Operation Manual via Internet



ROAD BLOCKING SYSTEMS



Office and Production site:
14 Promyslova str., 02088, Kyiv, Ukraine,
E-mail: sales@tiso.global

Tel.: +380 (44) 291-21-11
Fax: +380 (44) 291-21-02
www.tiso.global